

# KIPOR

## KIPOR POWER GENERATOR SHOP MANUAL



SINEMASTER  
DIGITAL GENERATOR

KGE3000Ti

## **Preface**

This manual covers the construction, function and servicing procedure of the KIPOR KGE3500Ti and Coast Distribution model KGE3000Ti generators. This manual is principally concerned with the generator specifications, function, troubleshooting and repair. There is a separate manual to cover engine overhaul which includes the starting systems.

Careful observance of the instructions contained in this manual will result in safe and quality service work.

All information, illustrations, directions and specifications included in this publication are based on the latest product information available at the time of approval for printing.

KIPOR POWER CO., LTD, reserves the right to make changes without incurring any obligation whatever. No part of this publication may be reproduced without written permission.

## Table of Contents

1. Specifications .....	3
1.1 Specifications.....	3
1.2 Characteristics .....	4
1.3 Performance curves .....	7
2. Service information .....	8
2.1 The importance of proper service .....	8
2.2 Important safety precautions .....	8
2.3 Service rules .....	9
2.4 Electrical Precautions .....	9
2.5 Serial number location.....	10
2.6 Maintenance standards .....	11
2.7 Torque values .....	12
2.8 Troubleshooting .....	13
3. Maintenance .....	24
3.1 Regular inspection schedule .....	24
3.2 Engine oil .....	25
3.3 Inspection of engine alert switch .....	26
3.4 Air filter maintenance.....	27
3.5 Sparkplug service .....	28
3.6 Adjusting of valve clearance.....	30
3.7 Fuel filter and fuel switch maintenance .....	31
4. Air filter and Muffler .....	32
4.1 Air filter .....	32
4.2 Muffler .....	33
5. Carburetor.....	34
5.1 Carburetor removal and installation .....	34
5.2 Stepping Motor disassembly and reassembly .....	35
5.3 Carburetor disassembly and reassembly.....	36
6. Control panel, charging adjustor and inverter unit.....	38
6.1 Assembly and disassembly .....	38
6.2 Inspection.....	38
7. Housing group , fuel tank assembly and disassembly .....	41
8. Generator, ignition coil and trigger .....	42
8.1 Generator .....	42
8.2 ignition coil and trigger.....	43

---

# 1. SPECIFICATIONS

---

## 1.1 SPECIFICATIONS

### Dimensions and weights

Model	KGE3000/3500Ti
Length	27 in (686mm)
Width	16.7 in (425mm)
Overall height	19.9 in (495mm)
Net weight	132 lbs, 60 kg

### Engine

Model	KG205
Type	4-stroke,overhead valve, single cylinder
Displacement in (cc)	12.0 (196)
Bore x stroke in.(mm)	2.68 x 2.13 (68x54)
Horsepower	4.0 @ 3600 rpm
Compression ratio	8.5:1
Cooling system	Forced air
Ignition system	T.C.I
Ignition timing	25 B.T.D.C
Spark plug	F7RTC
Carburetor	Float type, horizontal butterfly valve
Air cleaner	Semi-dry
Governor	Electronic control
Lubrication system	Forced splash
Oil capacity	.63 qt (0.6L)
Fuel tank capacity	3.43 gal (13L)
Starting system	Recoil starter and Electrical starter
Stopping system	Primary circuit ground
Fuel	Unleaded gasoline 87 octane

## Alternator

Model	KD 35
Generator type	Multi pole rotation type
Generator structure	Self-ventilation drip-proof type
Excitation	Self-excitation (Magnet type)
Voltage regulation system	PWM(Plush width modulation)
Phase	Three phase
Rotating direction	Clockwise (Viewed from the generator)
Frequency regulation	AC-DC-AC conversion (Inverter type)

## 1.2 CHARACTERISTICS

Model	KGE3000Ti/KGE3500Ti		
Maximum output watts/amps	3000/25 Amps		
Rated output watts/amps	2800/23 Amps		
Rated frequency	60 HZ		
Rated voltage AC	120V		
DC Voltage/current	12V/8.3 Amps		
Power factor	1.0cosφ		
Voltage variation rate-	Momentary	10%max.	
	Average	1.5%max.	
	Average time	3 sec. max.	
Voltage stability	±1%		
Frequency variation rate	Momentary	1%max.	
	Average	1%max.	
	Average time	1 sec. max.	
Frequency stability	±0.1%		
Insulation resistance	10MΩ min.		
AC circuit protector	26A(120V)		
DC circuit protector	14A		
Operating hours at rated load	7 Hours		
Noise level dBA @ 23' (7M)	62~67		

### 1.3 PERFORMANCE CURVES

The curves show performance of the generator under average conditions.

Performance may vary to some degree depending on ambient temperature and humidity.

The output voltage will be higher than usual when the generator is still cold, immediately after the engine starts.

AC external characteristic curve

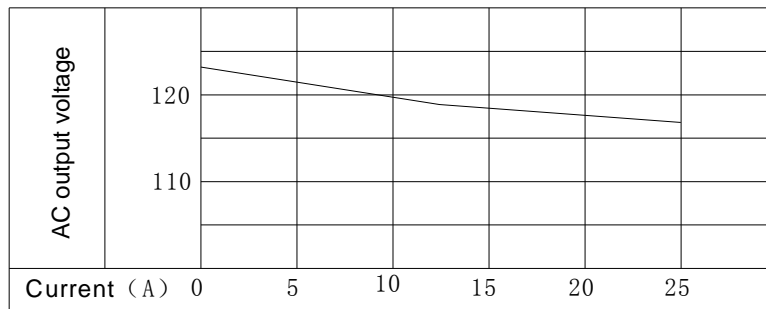

DC external characteristic curve

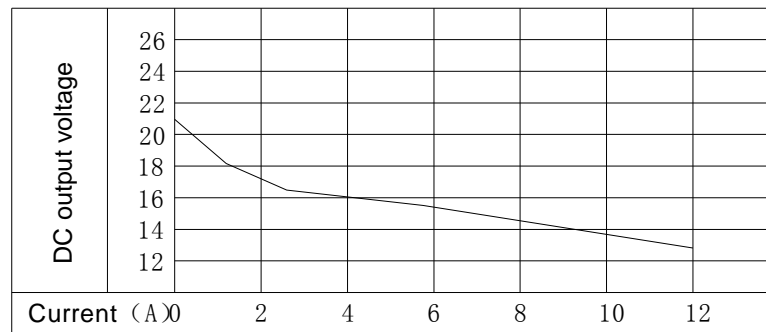

### 1.4 DIMENSIONAL DRAWING

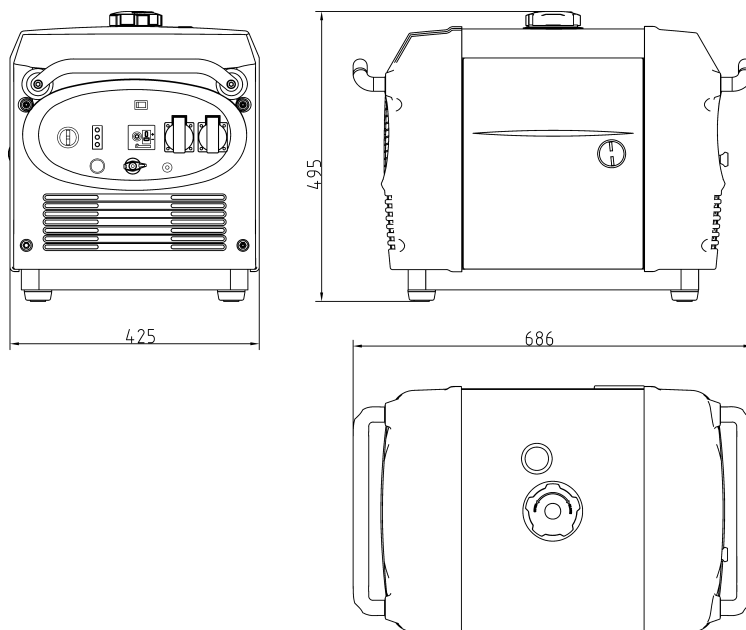

# 1.5 WIRING DIAGRAM

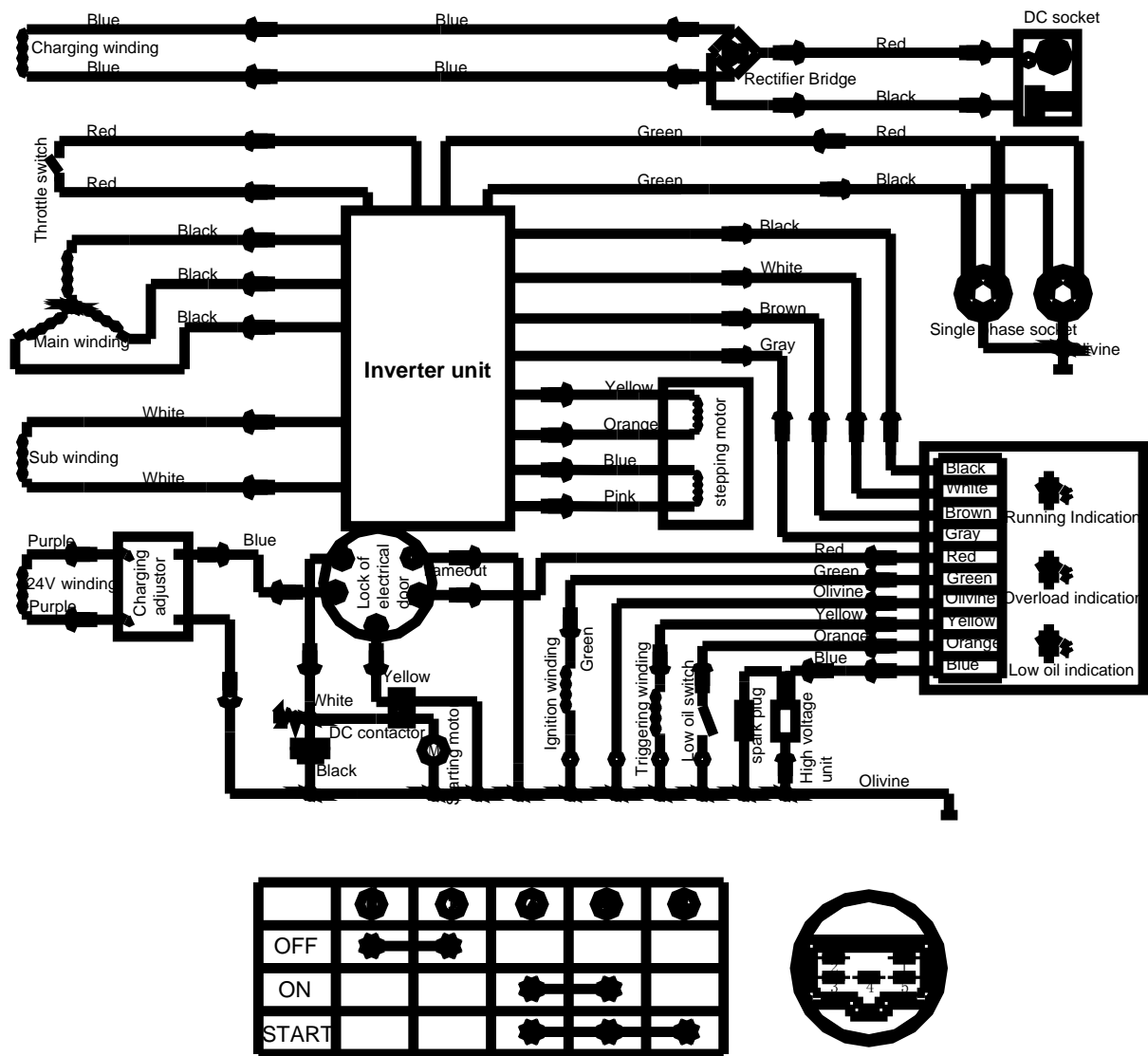

---

## 2. Service information

---

### 2.1 The importance of proper servicing

Proper servicing is essential to the safety of the operator and the reliability of the generator. Any error or oversight made by the technician while servicing can easily result in faulty operation and/or damage to the equipment or injury to the operator.

WARNING
<ul style="list-style-type: none"><li>■ Improper servicing can cause an unsafe condition that can lead to serious injury or death.</li><li>■ Follow the procedures and precautions in this shop manual carefully.</li></ul>



Some of the most important precautions are stated below.

### 2.2 Important safety precautions

Be sure you have a clear understanding of all basic shop safety practices and that you are wearing appropriate clothing and safety equipment. When performing maintenance or repairs, be especially careful of the following:

- Read the instructions before you begin, and be sure you have the tools and skills required to perform the tasks safely.
- Be sure that the engine is off before you begin any maintenance or repairs. This will reduce the possibility of several hazards:
  - Carbon monoxide poisoning from engine exhaust.
  - Burns from hot parts.
  - Injury from moving parts.
- Do not run the engine unless the instructions tell you to do so. Keep your hands and clothing away from rotating parts.
- To reduce the possibility of fire or explosion, exercise extreme caution when working around gasoline. Use only a nonflammable solvent, not gasoline, to clean parts. Keep cigarettes, sparks and flames away from all fuel-related parts.

### **2.3 Service rules**

- Use genuine KIPOR or KIPOR-recommended parts and lubricants or their equivalents. Parts that do not meet Kipor's design specifications may damage the engine.
- Use the special tools designed for the product.
- Always install new gaskets, O-rings, etc. when reassembling components.
- Clean parts in cleaning solvent upon disassembly. Lubricate any sliding surfaces before reassembly. After reassembly, check all parts for proper installation and operation.
- Many screws used in this machine are self-tapping. Be aware that cross-threading or over tightening these screws will strip the threads and ruin the hole.
- Use only metric tools when servicing this engine. Metric bolts, nuts and screws are not interchangeable with non metric fasteners. The use of incorrect tools and fasteners will damage the engine.

### **2.4 Electrical precautions**

- Hold the connector body to disconnect the connector. Do not disconnect by pulling the wire harness. To disconnect the locking connector, be sure to unlock first, and then disconnect.
- Check the connector terminals for bend, excessive extrusion, missing terminals, or other abnormalities before connecting the connector.
- To connect, insert the connector as far as it goes. If the connector is a locking type, be sure that it is locked securely.
- Check the connector cover for breakage and check whether the connector female terminal is not opened excessively. Then, connect the connector securely. Check the connector terminal for rust. Remove the rust using an emery paper or equivalent material before connecting the connector.
- Set the harness clips in the specified places of the frame securely, and secure the wire harnesses.
- Clamp the cables securely.

- Clamp the wire harnesses securely so that they do not interfere with the rotating parts, moving parts and hot parts.
- Route and connect the wire harnesses properly. Be sure that the harnesses are not slack, twisted or pulled overly taut.
- Route the wire harnesses properly so that they do not contact sharp edges and corners and the end of the bolts and screws on the body.
- If a wire harness must contact the end of the bolts or screws or sharp edges and corners, protect the contact part of the harness with a loom or by winding with electrical insulating tape. If the wire harness has a grommet, set the grommet securely.
- Take care not to pinch the wire harnesses during installation of a part. If a wire harness has damaged insulation, repair by winding with electrical insulating tape.
- When using an electrical tester like a volt/ohm meter or clamp on meter, read the manufacturer's operating instructions carefully before operating the tester. Be sure that the tester battery is fully charged and the meter is functioning properly

## 2.5 Serial number location

The engine serial number is stamped at the underside of engine side cover. Refer to this number when ordering or making technical inquiries.

Engine serial number

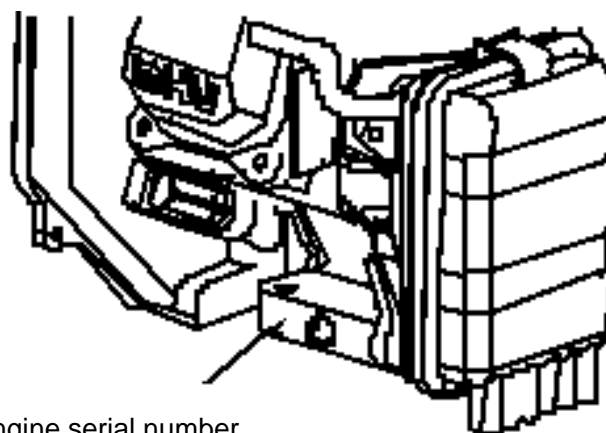

## 2.6 Maintenance standards

### Engine

Part	Item	Standard in. (mm)	Service limit
Cylinder	Sleeve I.D.	2.67~2.68 (68.02~68.04)	2.68 (68.17)
Piston	Skirt O.D	2.68~2.68 (67.97~67.99)	2.68 (67.62)
	Piston-to-cylinder clearance	.0016~.0023 (0.040~0.060)	.0047 (0.12)
	Pin bore I.D.	18.002~18.008	18.042
Piston pin	O.D	.708~.709 (17.990~18.000)	.709 (17.95)
	Pin-to-piston clearance	.0001~.0071 (0.002~0.018)	.0003 (0.080)
Piston ring	Ring width Top	1.420~1.440	1.32
	Second	1.420~1.440	1.32
	Ring side clearance Top/second	0.02~0.06	0.15
	Ring end clearance Top/second	0.150~0.350	1.0
Connecting rod	Small end I.D	.7089~.7093 (18.006~18.017)	0.711 (18.07)
	Big end I.D	1.182 (30.015~30.025)	1.184 (30.07)
	Big end oil clearance	.0018~.0024 (0.046~0.060)	0.12
	Big end side clearance	.0177~.0276 (0.45~0.70)	.0394 (1.0)
Crankshaft	Crank pin O.D.	29.960~29.975	29.90
Valve	Valve clearance Intake	.0039±.0008 (0.10±0.02)	
	Exhaust	.0059±.0008 (0.15±0.02)	
	Stem OD Intake	.215~.216 (5.46~5.48)	.211 (5.35)
	Exhaust	.215 (5.45~5.47)	.211 (5.35)
	Vessel I.D Intake/Exhaust	.216-.217 (5.500~5.518)	.219 (5.56)
	Clearance of valve and vessel Intake	.0008~.0023 (0.020~0.058)	.0039 (0.1)
	Exhaust	.00~.0027 (0.30~0.068)	.0047 (.12)
Seat width Intake/Exhaust	.031~.047 (0.8~1.2)	.079 (2.0)	
Valve spring	Free Length Intake/Exhaust	1.20 (30.5)	1.14 (29)
Cam wheel	Cam height Intake/Exhaust	1.09~1.10 (27.63~27.91)	1.08 (27.34)
	I.D (shaft bore)	1.09~1.10 (27.68~27.94)	1.08 (27.34)
Camshaft	O.D	.550~.551 (13.966~13.984)	.553 (13.92)
Valve lifter	I.D (shaft bore)	.313~.314 (7.96~7.98)	.310 (7.87)
Crankcase cover	Camshaft Bearing I.D.	.550~.552 (14.000~14.027)	.553 (14.05)
Cylinder block	Valve lifter I.D.	.315~.316 (8.000~8.015)	.317 (8.06)
	Camshaft Bearing I.D.	.550~.552 (14.000~14.027)	.553 (14.05)
Spark plug	Clearance	.024~.031 (0.6~0.8)	—
Ignition coil	Resistance Primary side	0.8—1.3Ω	—
	Second side	15—21kΩ	—
Pulse coil (Trigger)	Air gap	.020~.030 in. (0.5~0.75)	—
	Resistance	80~130Ω	—
Starting relay	Resistance	3.8~4.1Ω	—

## Generator

Part	Item	Type	Standard ( $\Omega$ )	Service limit
			120V	
Ignition coil	Resistance	Yellow/Green—Green	0.26~0.28	—
Outer charging winding coil	Resistance	Blue-Blue	0.12~0.15	—
Inner charging winding coil	Resistance	Purple-purple	0.19~0.21	—
Sub winding coil	Resistance	White—White	0.12~0.14	—
Main winding coil	Resistance	Black—Black	0.8~1.1	—

## 2.7 Torque values

Item	Thread dia. X pitch	Tightening torque	
		Ft/lbf	N.m
Connecting rod bolt	M7	10.3~11.8	14~16
Cylinder head bolt	M8×60	20.7~23.6	28~32
Spark plug	M14×1.25×19	18.4~22.2	25~30
Crankcase cover	M8×30	14.75~17.0	20~23
Flywheel nut	M14×1.5	59.0~66.42	80~90
Tightening bolt of rocker arm base	M6×0.75×33	14.75~17.0	20~23
Adjusting nut of rocker axis	M6×0.75	7.4~8.8	10~12
Standard torque	M5 bolt、nut	4.4~5.9	6~8
	M6 bolt、nut	5.9~7.4	8~10
	M8 bolt、nut	14.8~17.0	20~23
	M10 bolt、nut	40.6~44.3	55~60

### Note:

Use standard torque values for fasteners that are not listed in this table.

## 2.8 Troubleshooting

### A. General symptoms and possible causes

Symptom	Cause(s)	Remedy
Engine does not start or hard starting	Carburetor float chamber contains stale gasoline, or no fuel reaches carburetor	Drain old fuel, clean and /or replace
	Fuel tank tube clogged	Inspect
	Fuel filter clogged	Clean
	Carburetor failure	Clean and/or replace*
	Spark plug cap disconnected	Install securely
	Ignition coil failure	Inspect and replace
	Spark plug failure	Inspect and replace
	Oil level switch (Low oil alarm) failure	Inspect and replace
	Igniting device failure	Inspect and replace
	Pulse coil (Trigger) failure	Inspect and replace
	Choke air inlet not controlled properly	The position can be full open or half open
Engine speed does not stabilize, too high or too low	Carburetor failure	Adjust and/or disassemble and clean
	Throttle control motor (stepping motor) failure	Inspect
	Generator failure	Troubleshoot
	Inverter unit failure	Troubleshoot
	Valve clearance misadjusted	Adjust

\* Carburetor replacement parts are not available. No adjustments or overhaul is permitted under current EPA/CARB guidelines.

## B. Hard starting

If the engine does not start or is hard starting after reassembly, check to see whether the throttle valve is at the full open position.

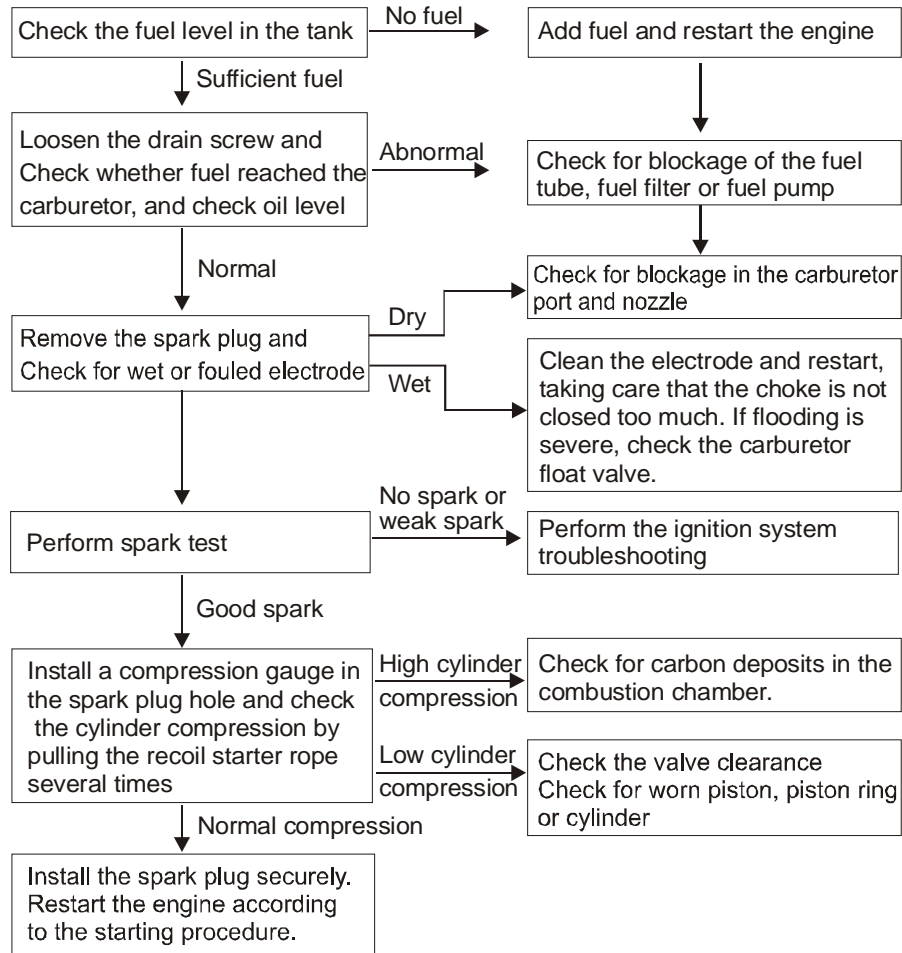

- Cylinder compression check

1. Remove the spark plug cap and spark plug
2. Install a compression gauge in the spark plug hole. Pull the recoil starter rope several times with force and measure the cylinder compression.

Cylinder compression	0.45Mpa/600rpm
----------------------	----------------

- Ignition system fault inspecting and repair- Spark Test

- a. Remove the spark plug.
- b. Install the spark plug onto spark plug cap.
- c. Turn the ignition switch of engine to the position "ON". Then ground the spark electrode to the cylinder head cover and pull the start motor rope to check if sparks jump across the

electrode.

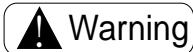

Warning

### Warning

- Do not pull the recoil starter rope while touching the high tension wire with a wet hand. High voltage is generated which is dangerous. Be sure to ground the spark plug and hold the plug cap with an insulated pair of pliers to perform the spark test.
- Make sure no spilled fuel is anywhere on the engine and no fuel is on the spark plug  
Keep sparks and any other combustible source away from the spark plug hole.

C. Engine does not start with sufficient oil in the crankcase.

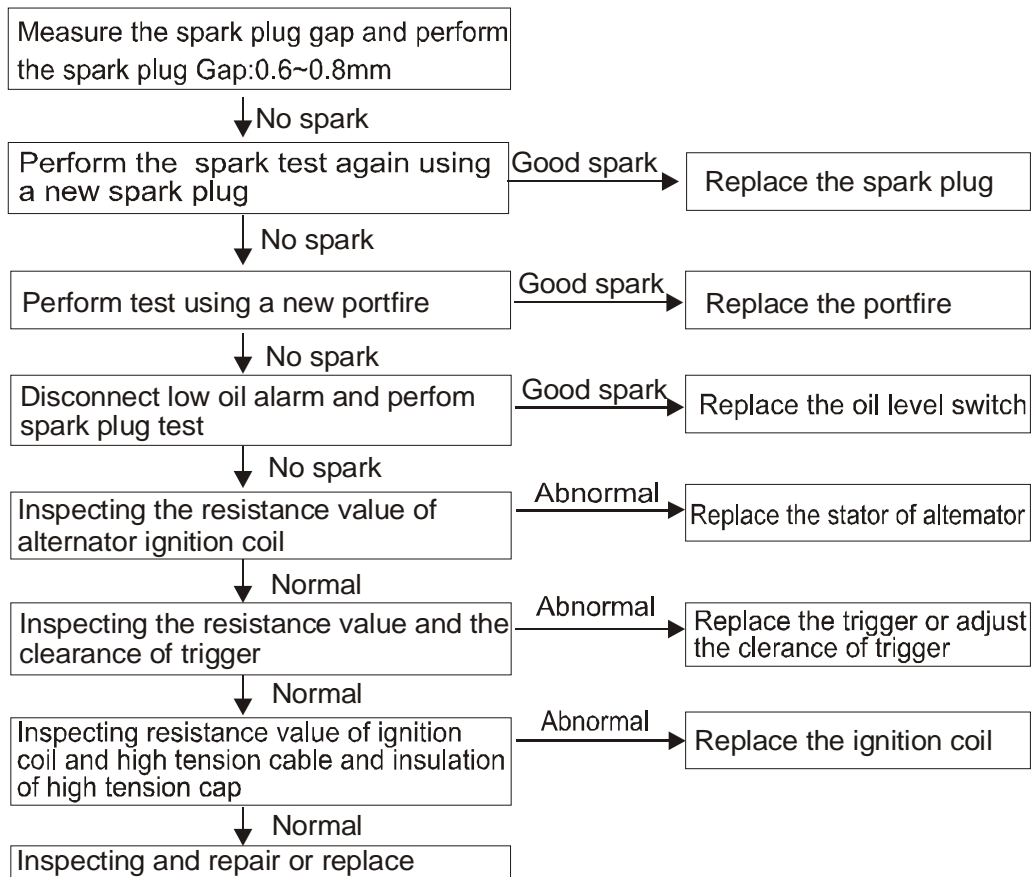

D. Engine oil level is low, but engine does not stop.

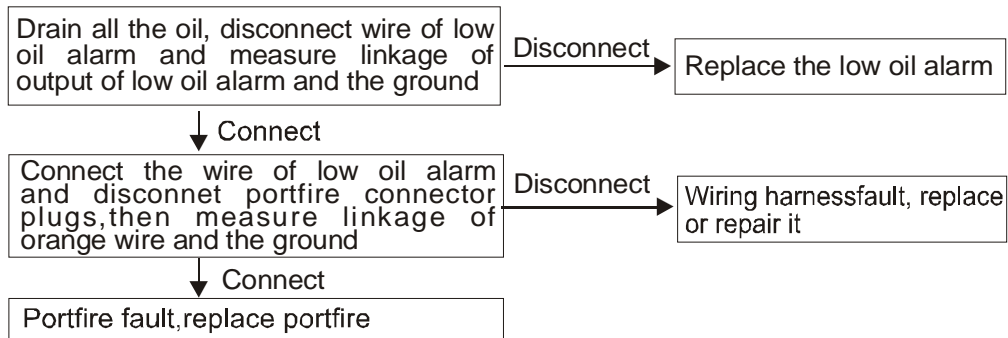

E. Engine starts but then stalls ( throttle is installed in proper position )

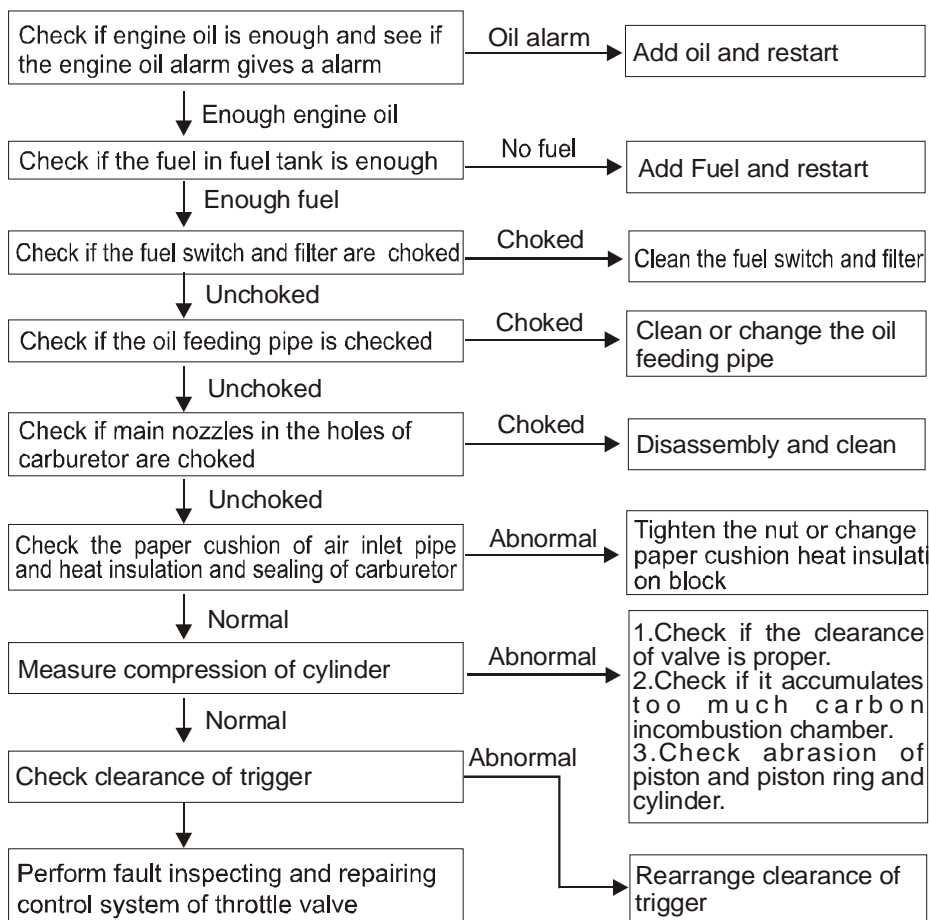

F. Engine speed does not increase or stabilize.

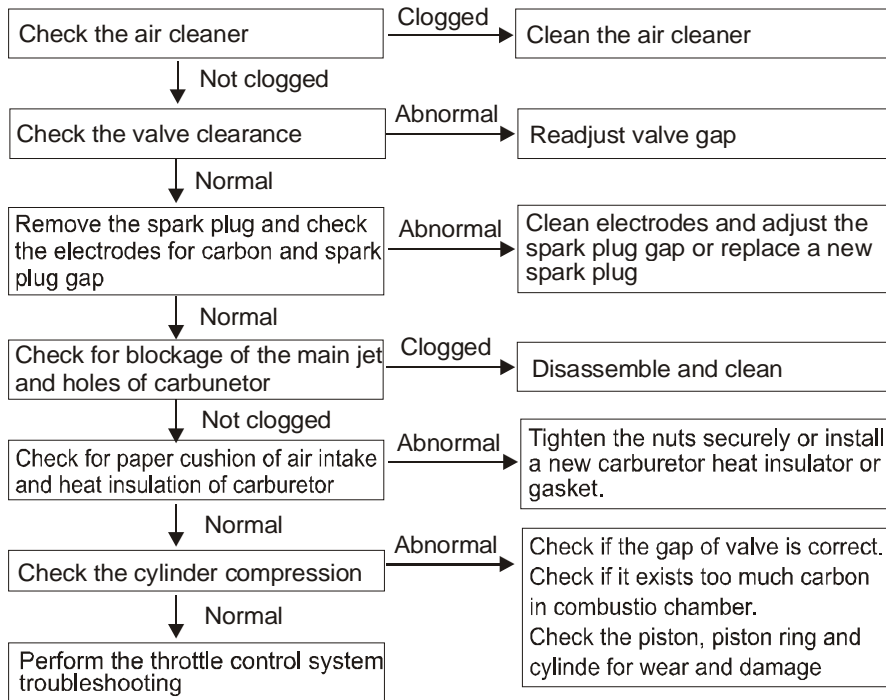

G. Smart throttle Problems

1. Engine speed is too high, hunting or too low.

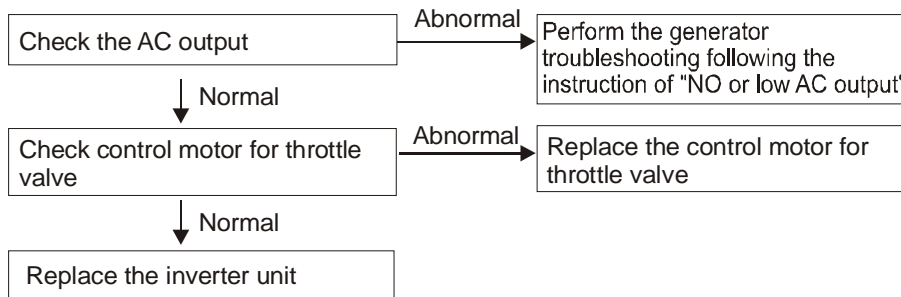

2. Smart Throttle system does not work under no load. (engine speed does increase after connecting load with Smart Throttle system ON.)

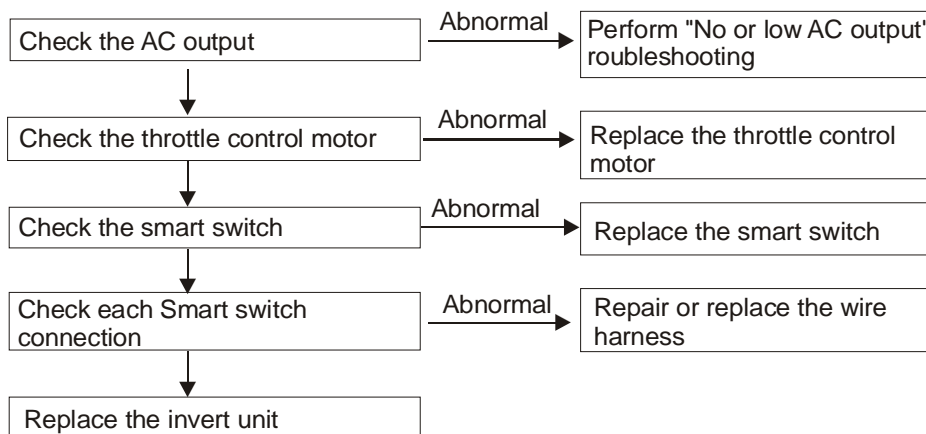

### H. No or Low AC output

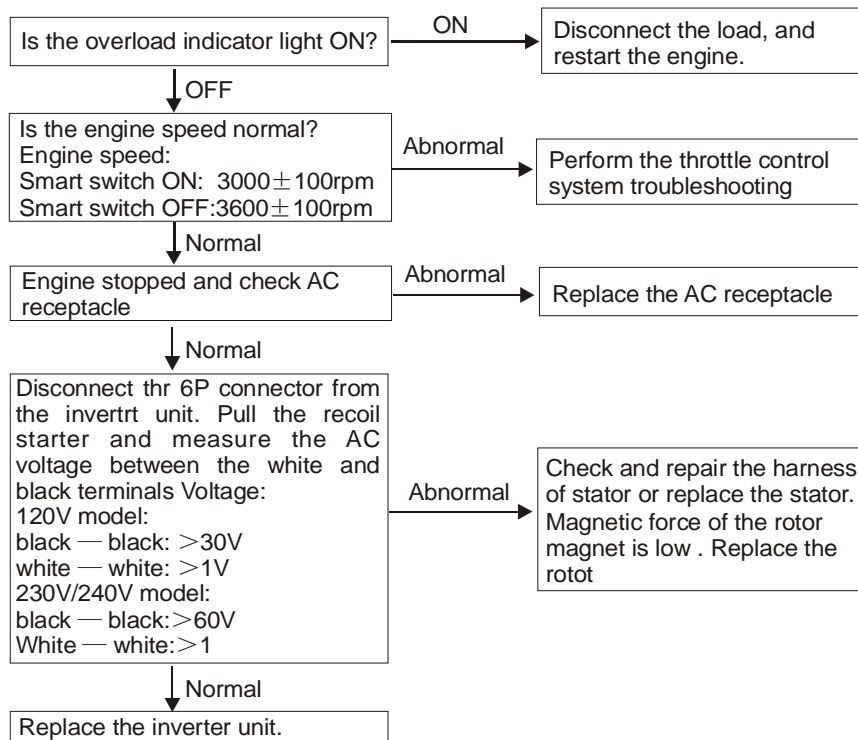

The stator output may be checked with the engine running. Disconnect the 6P connector from the inverter unit. starting Check voltage between pins 1 & 4, pins 2 & 4, and pins 1 & 2. There should be 280 to 330 Volts AC. If one or more of the three tests fail, the problem is either a damaged wire harness or a defective alternator.

### I. No DC output

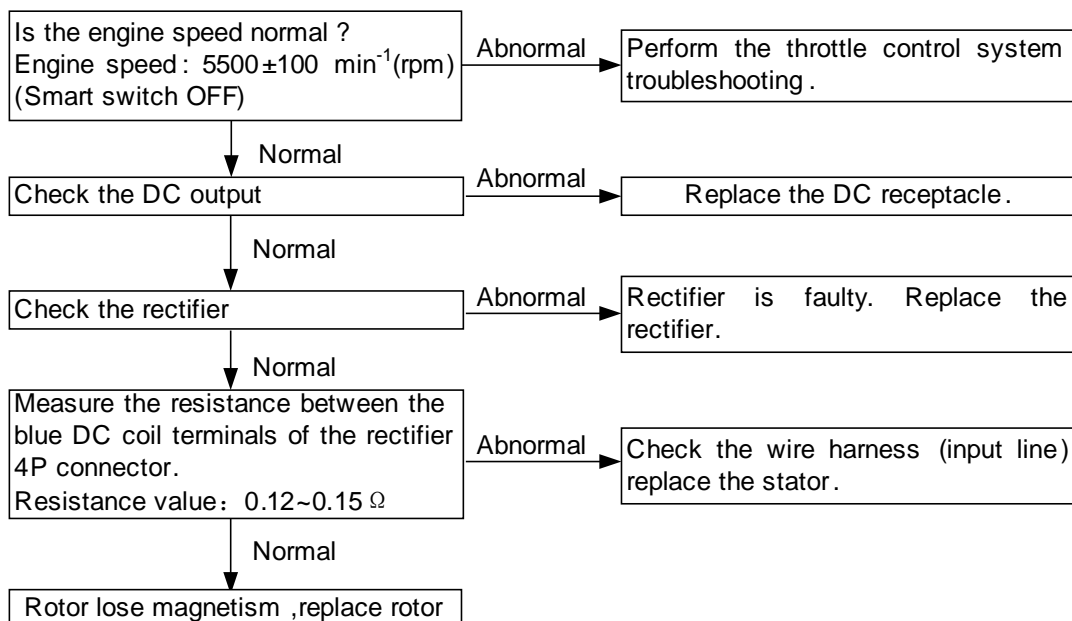

J. Engine will not start Electrically

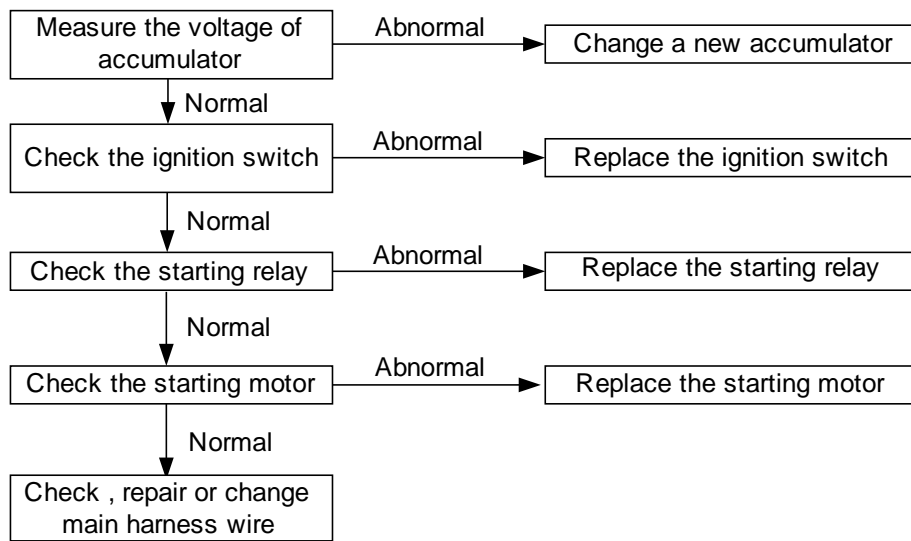

K. Starting Battery Will Not Hold a Charge

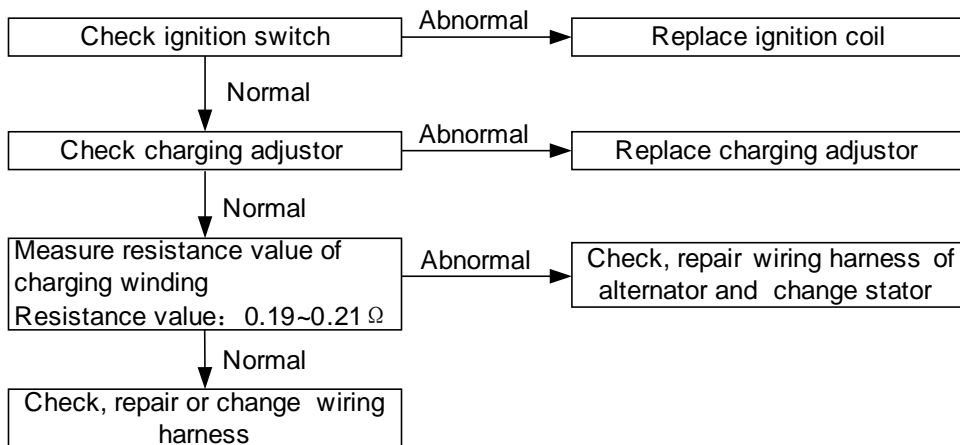

## 3 MAINTENANCE

### 3.1 Maintenance schedule

Regular service period <sup>①</sup>		Each use	First month or 10 Hrs.	Every 3 months or 50Hrs.	Every 6 months or 100 Hrs.	Every year or 300 Hrs.
Item perform at every indicated month or operating hour interval, whichever comes first						
Engine Oil	Check	•				
	Replace		•		•	
Air cleaner	Check	•				
	Clean			• <sup>②</sup>		
Spark plug	Clean-Adjust				•	
Spark catcher	Clean				•	
Valve clearance	Check-Adjust					• <sup>③</sup>
Fuel tank and filter	Clean					• <sup>③</sup>
Fuel line	Check	Every 2 year (Replace if necessary <sup>③</sup> )				

Note:

- ① Interval operating time in normal troubleshooting.
- ② When it is used in dusty place, filter should be cleaned every 10 hours or everyday.
- ③ Maintenance should be carried out by the qualified technicians.

### 3.2 Engine Oil

#### A. Checking Oil Level

Engine should be shut off and generator be on level ground when checking the oil level.

- (1) Remove the oil dipstick, check oil level.

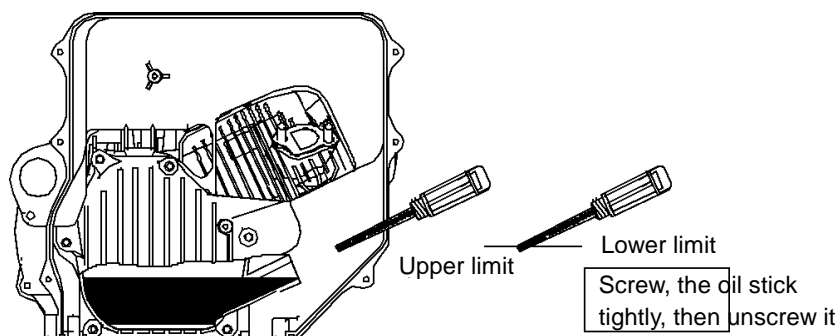

(2) Add the proper viscosity engine oil to the upper limit if oil level is low. Be careful to over fill.

#### B. Changing engine oil

(1) Remove the oil dipstick and unscrew oil drain plug to drain used oil.

(2) Replace the drain plug and secure tightly.

(3) Add the proper viscosity oil to the upper oil limit level.

(4) Reinstall the dipstick and screw it tightly

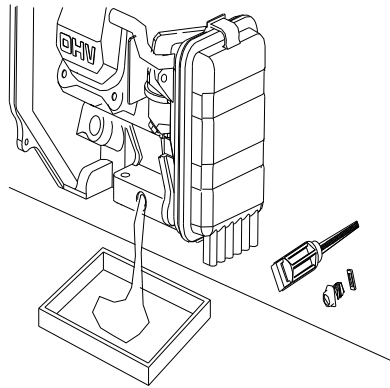

### 3.3 Inspection of the Oil Alert Switch

(1) Disconnect the orange connection of the oil alert wire when engine is running, and ground one end to the engine block as shown below to ensure that the engine will stop when the oil alert lamp is lit.

NOTE: On early models, the oil alert connection is in the back of the generator on the opposite side of the service door.

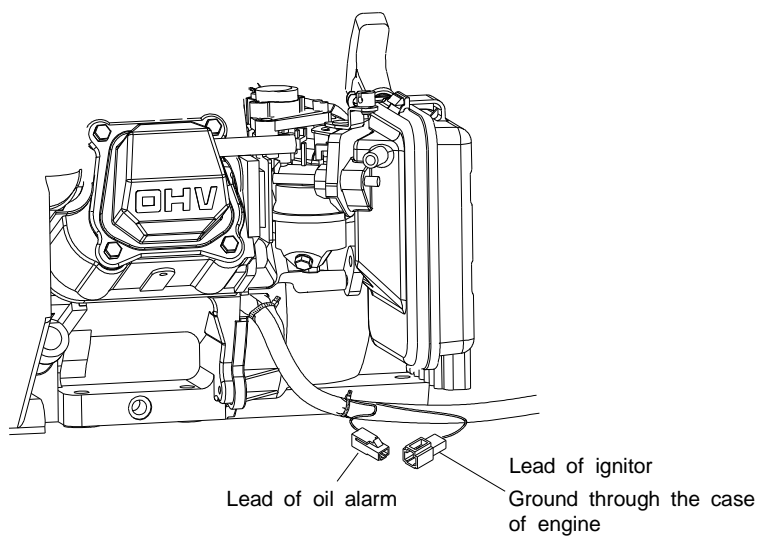

(3) Stop the engine and disconnect the orange wire of the oil alert after insuring that the engine oil is at the proper level. Test the conductivity between the end shown in the figure and the case of engine, No conductivity indicates a normal condition.

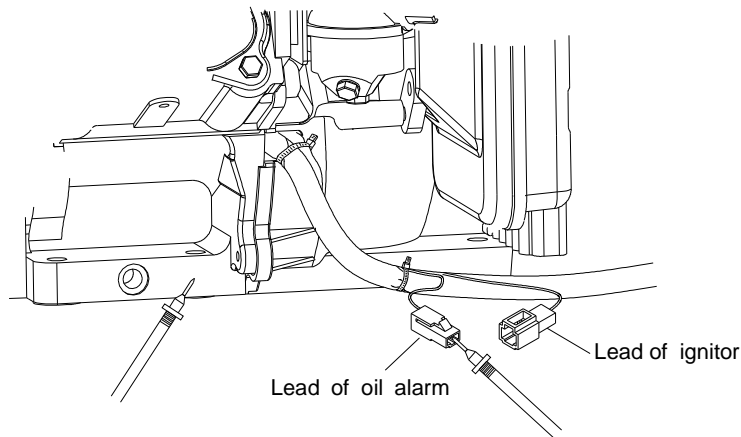

(4) Drain all the engine oil in the engine repeat the test. The switch is working properly if there is normal conductivity.

### 3.4 Air Filter Maintenance

(1) Open the service door.

(2) Open the cover of air filter and take out the filter element.

(3) Blow the inner side of filter element using compressed air or lightly knock it to remove dirt. If any dirt remains, change the element. Be sure to use a genuine Kipor element to maintain a proper seal and avoid engine damage.

(4) Reinstall the filter element and close the service door.

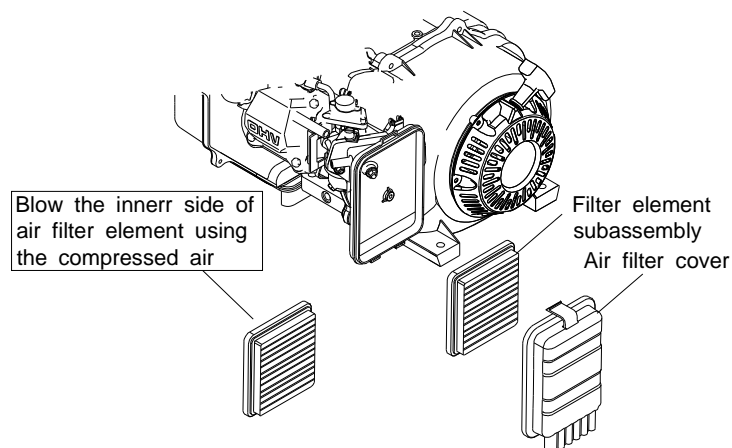

### Attention

■ Don't operate the generator without the filter element in place or serious engine damage may result.

## 3.5 Spark Plug Servicing

- (1) Remove the spark plug cap, and use a spark plug wrench to remove the spark plug.
- (2) Check the condition of the porcelain insulator. Replace the spark plug if it is chipped or cracked.
- (3) Remove carbon or other deposits with a stiff wire brush. Check if the sealing washer is damaged.
- (4) Check the resistance of the spark plug and replace it if it is not within the specified resistance value.

Resistance of spark plug	3~9K $\Omega$
--------------------------	---------------

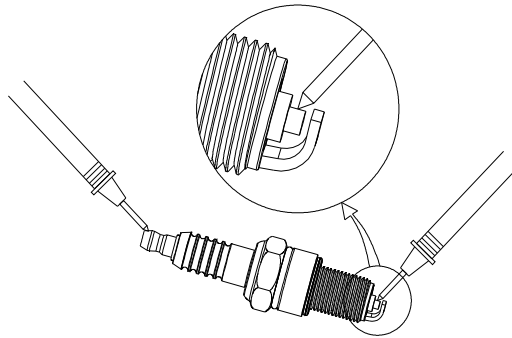

- (5) Use a feeler gauge to check the electrode gap. Adjust the electrode to the following specification by carefully bending the side electrode to the specified value.

Clearance of spark plug	.024~ .031 in 0.6~0.8mm
Standard spark plug	F7RTC

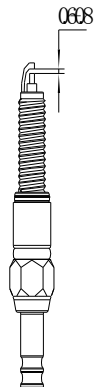

(6) Reinstall the spark plug and screw it tightly after regulating, the specified torque is 18.44~22.13 ft lbs. (25~30 N.m).

### 3.6 Adjusting valve clearance

#### Attention

Valve adjustment should only be performed on a cool engine.

(1) Remove valve cover.

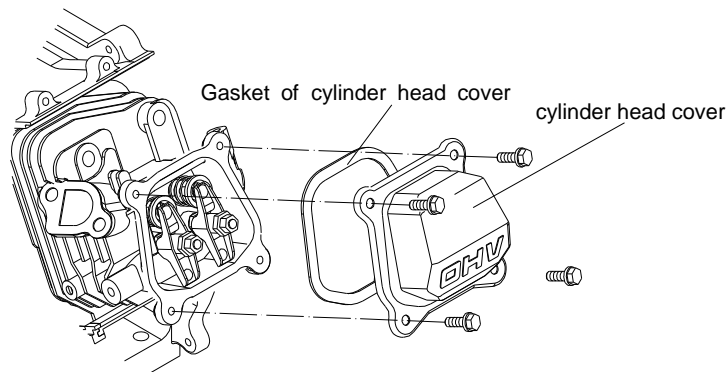

(2) Pull the starter rope gently and set the piston in top dead center (the scale of starting wheel should align with the sign “△” on the air guiding cover)

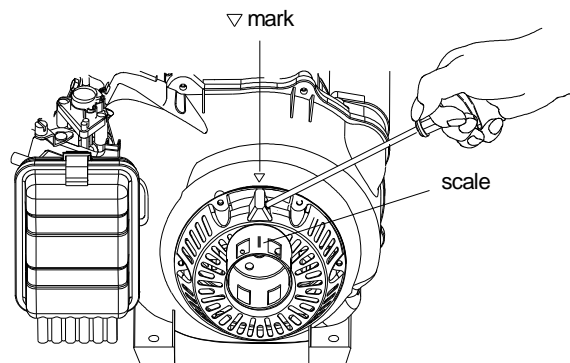

(3) Insert a feeler gauge into the gap between rocker and valve to measure the valve clearance.

Valve Clearance	Intake: $0039 \pm .0008$ in ( $0.10 \pm 0.02$ mm) Exhaust: $.0059 \pm .0008$ in ( $0.15 \pm 0.02$ mm)
-----------------	--

(4) If adjustment is necessary, proceed as follows:

- a. Hold rocker axis using the wrench and loosen the lock nut.
- b. Loosen the lock nut of rocker axis to gain the specified intake and exhaust valve clearance.
- c. Hold rocker axis using a wrench and tighten the lock nut.
- d. Check the clearance of valve after adjustment.

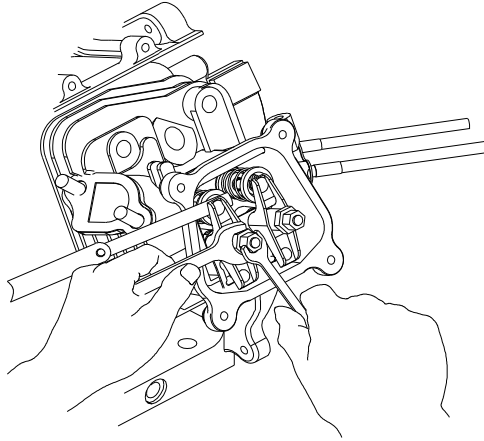

### 3.7 Fuel filter and fuel switch maintenance

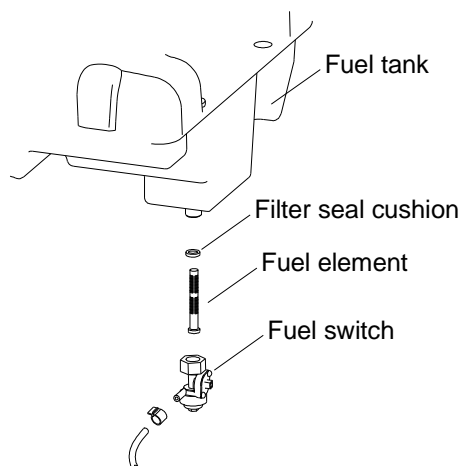

#### Attention

- Keep smoking materials and any open flames away during fuel system maintenance.
- Make sure that there is no leaking fuel after service.

(1) Drain all fuel from the tank and carburetor and remove the fuel tank.

(2) Loosen the nuts between fuel switch and fuel tank and remove the filter element.

(3) Turn the fuel switch to the open position. Clean it with a suitable solvent then blow dry with compressed air.

(4) Remove any foreign material from the fuel filter and insure the filter net is undamaged. Replace if necessary

(5) Properly install seal cushion and filter element and tighten the nuts between fuel switch and the fuel tank.

---

## 4. Air Filter and Muffler

---

### 4.1 Air filter

#### ● Disassembly and assembly

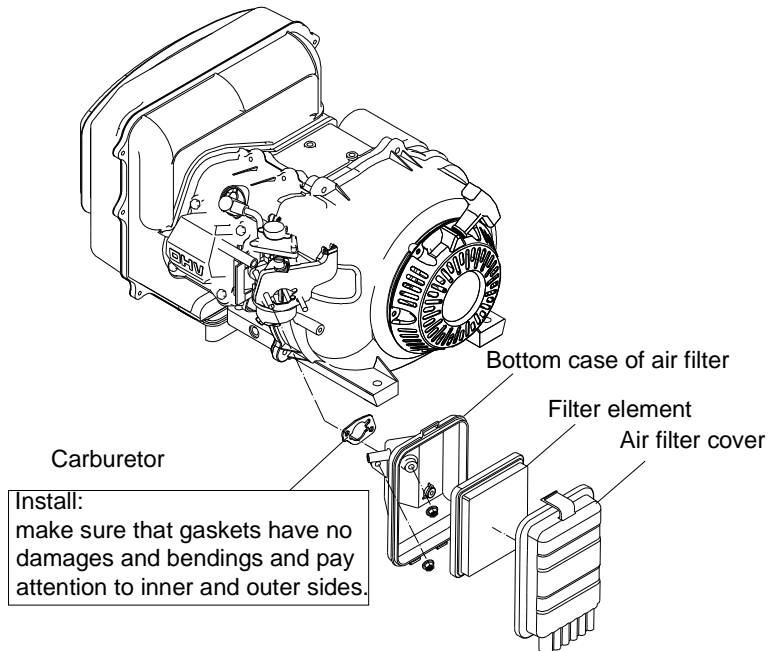

### 4.2 Muffler

#### ● Disassembly and assembly

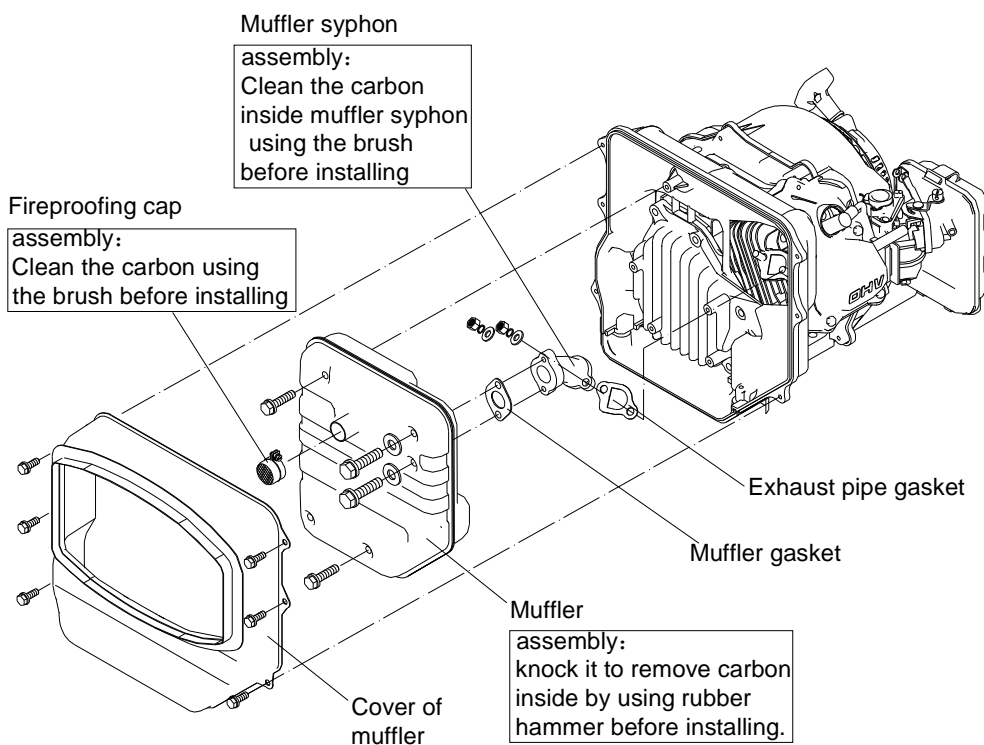

---

## 5. Carburetor

---

### Attention

- Loosen the gasoline drain bolts before disassembly to drain fuel in the carburetor.
- Smoking and any source of combustion are strictly forbidden in the process of disassembly.

### 5.1 Carburetor removal and installation

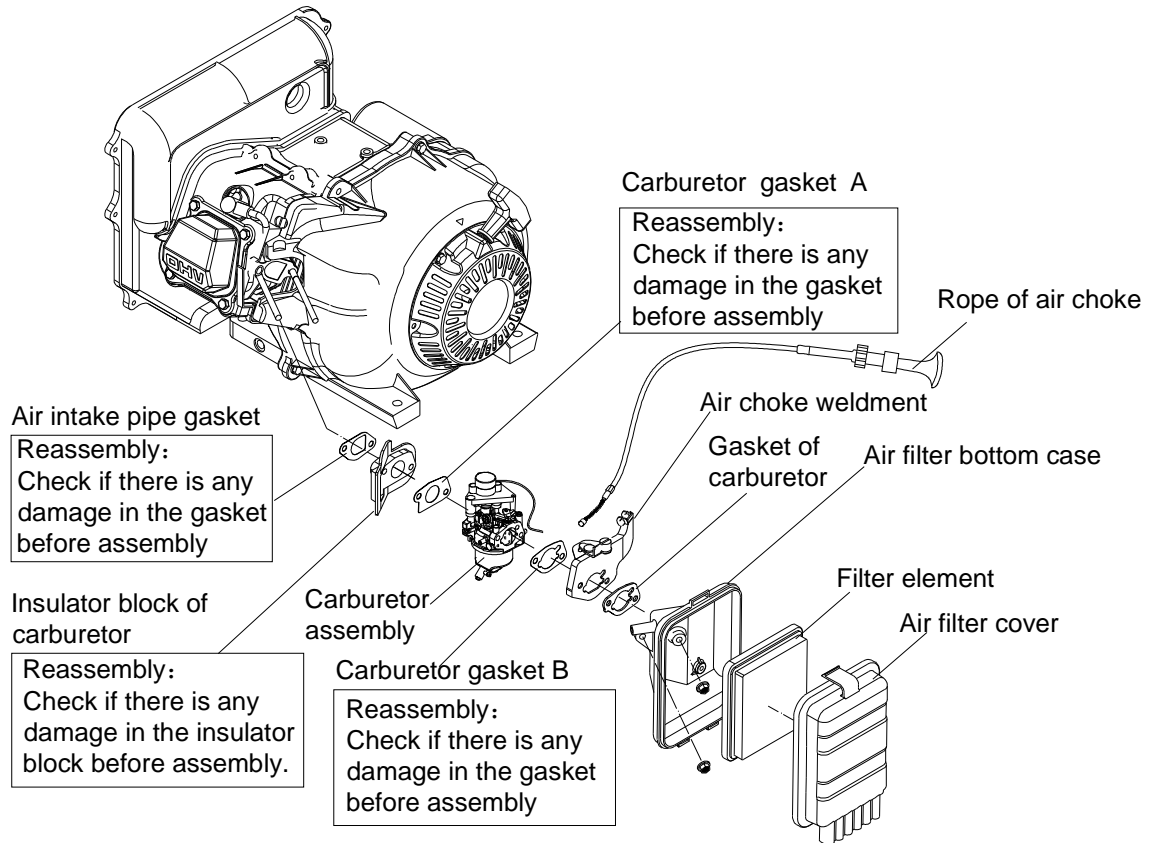

## 5.2 Stepping motor disassembly and reassembly

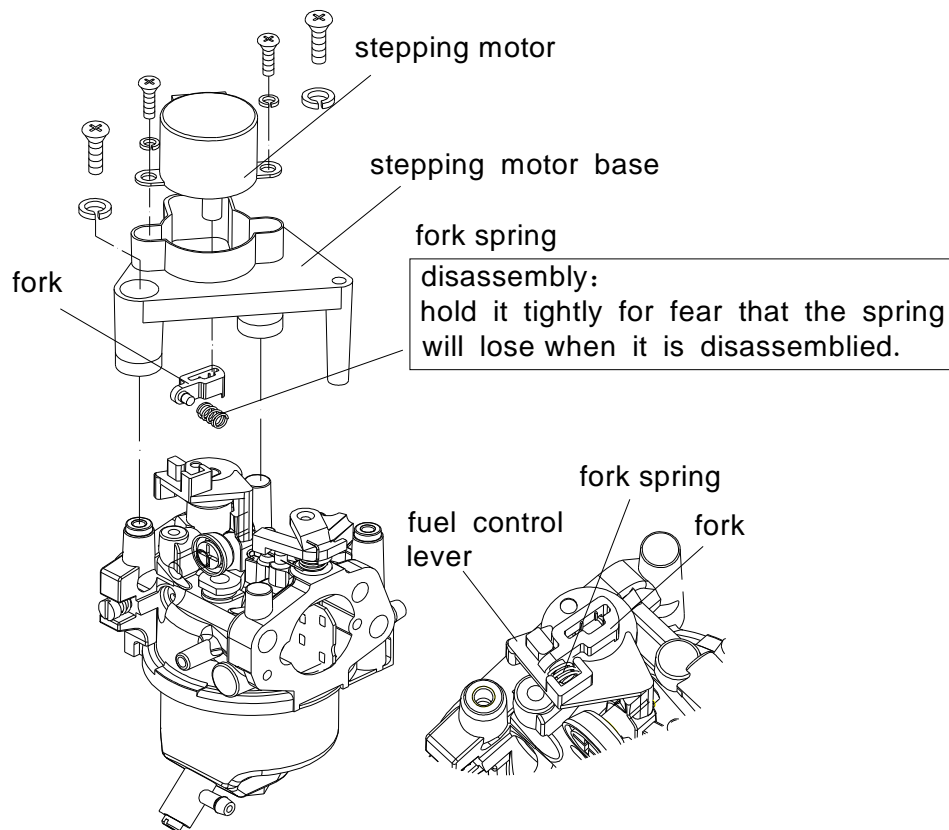

### 5.3 Carburetor disassembly and reassembly

NOTE: With the exception of changing the main jet, no adjustments, modifications, or other maintenance is permitted on EPA and CARB certified engines. This includes any Kipor generator ever sold in North America. This drawing is for information only.

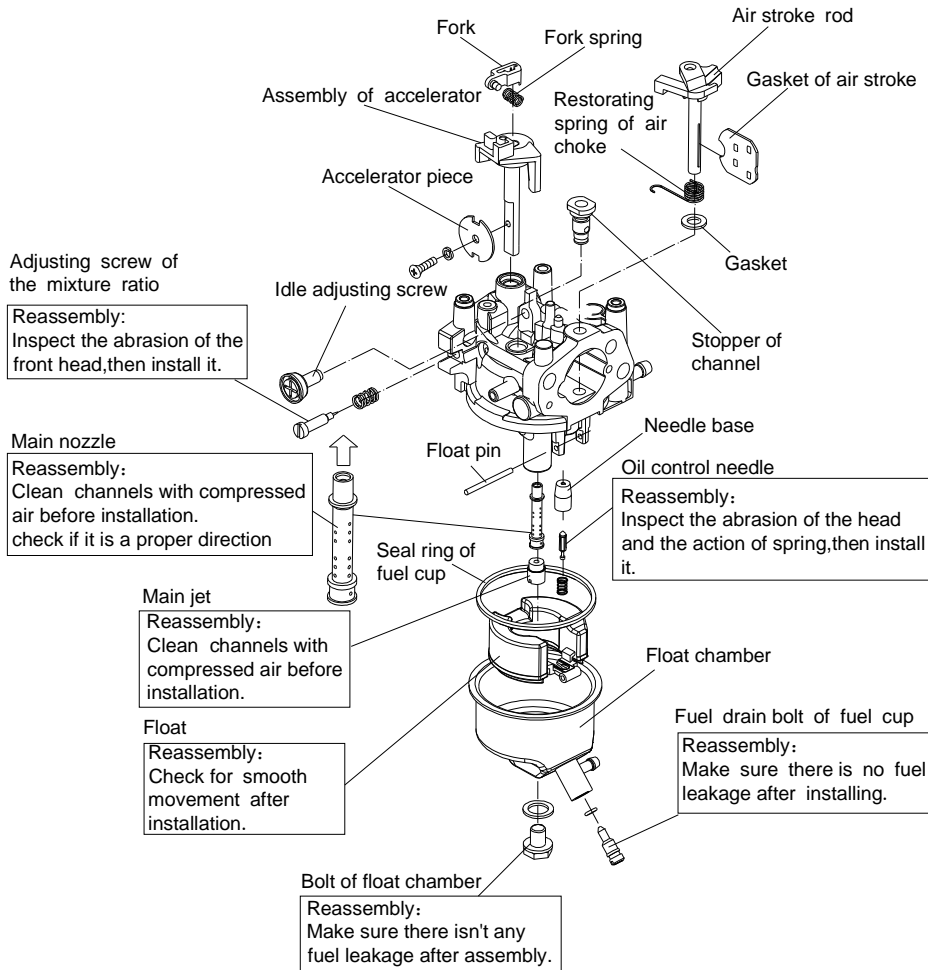

#### ● Stepping motor

Measuring the resistance of stepping motor leading wires

Specified resistance	1 and 3: 45~55 Ω
	2 and 4: 45~55 Ω

Replace the stepping motor if the resistance value exceeds the specified range.

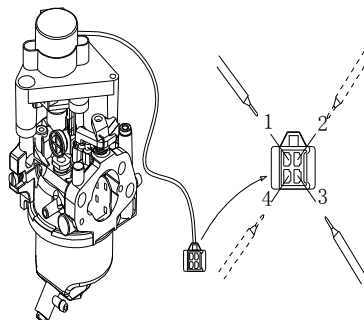

## 6. Control panel, charging adjustor and inverter unit

### 6.1 Disassembly and assembly

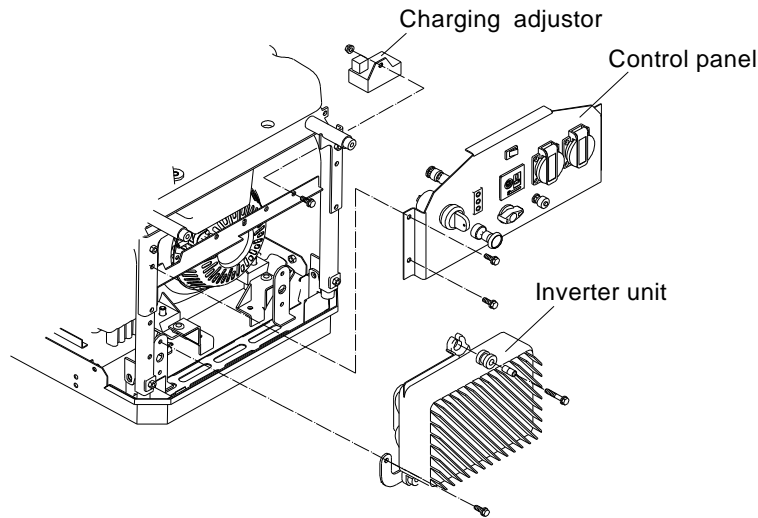

### 6.2 Inspection

#### A. Smart Throttle switch

There should be continuity between both poles of the switch when placed in the on position. If not, replace the switch.

#### B. Ignition Module (3 in one switch)

Pull out 10P connector plug from the ignition module. Connect an ohm meter to ground and measure the resistance in the various 10p connector pins to measure the resistance. Use the following chart for reference:

Color	Circuit unit	Specified resistance value
Blue	Primary ignition coil	0.8~1.3 Ω
Orange	Low oil alarm	It is not lit under the condition that oil position is normal
Yellow	Trigger coil	80~130 Ω
Kelly	Grounding wire	Put through
Green	Ignition device power coil winding	0.26~0.28 Ω
Red	Engine fire extinguishing switch (one foot)	The Ignition switch is put through when it switches on, otherwise it will disconnect.

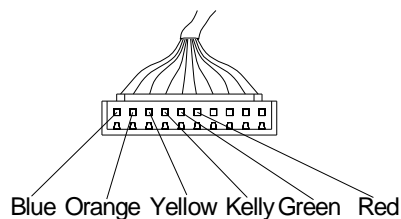

C. Ignition switch

Check connection between each group terminal, the results should agree with the states listed in the following table, otherwise it should be replaced.

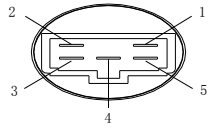

	①	③	②	④	⑤
OFF	●	●			
ON			●	●	
START			●	●	●

D. Rectifier

Use the  $\rightarrow|+ \rightsquigarrow$  item of instrument to test connection between each group feet of rectifier (plus voltage falls), the results must agree with standard listed in the following table.

	Positive Electric pen				
	Negative Electric pen				
		1	2	3	4
1			Block	Block	Block
2		Connect		Block	Block
3		Connect	Connect		Connect
4		Connect	Block	Block	

(1) Negative terminal (-) (2) AC terminal (~)

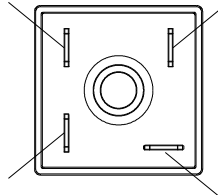

(4) AC terminal (~) (3) Negative terminal (+)

E. Charging adjustor

Start the engine and disconnect the wire of charging adjustor with two electrodes of the battery, then measure the voltage between output terminal of charging adjustor and grounding wire.

DC charging voltage	13~14V
---------------------	--------

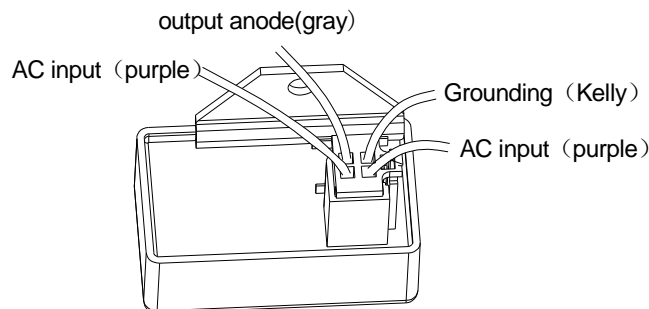

## 7. Housing group and Fuel tank

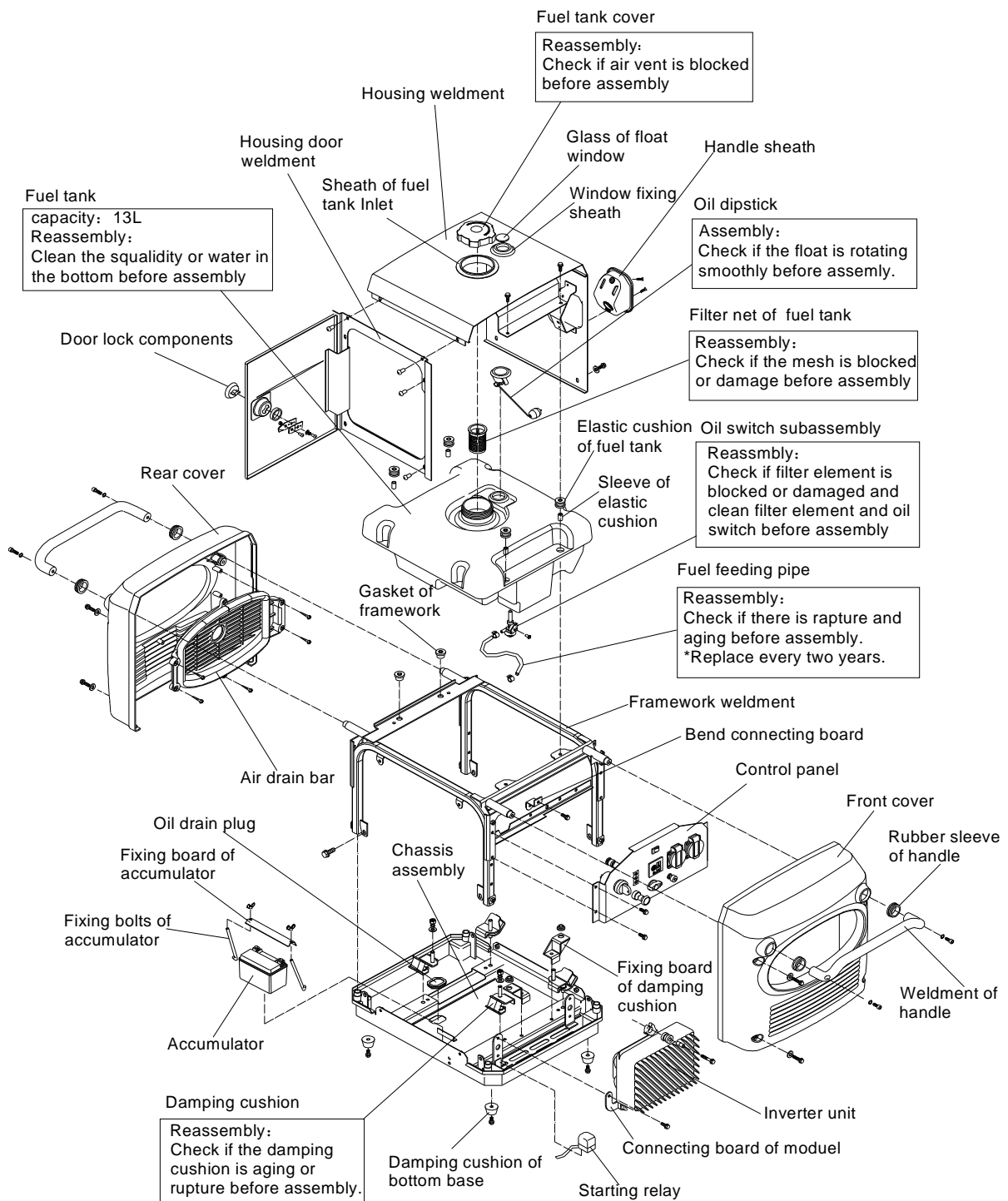

## 8. Generator, ignition coil, trigger

### 8.1 Generator

#### A. Disassembly and Reassembly

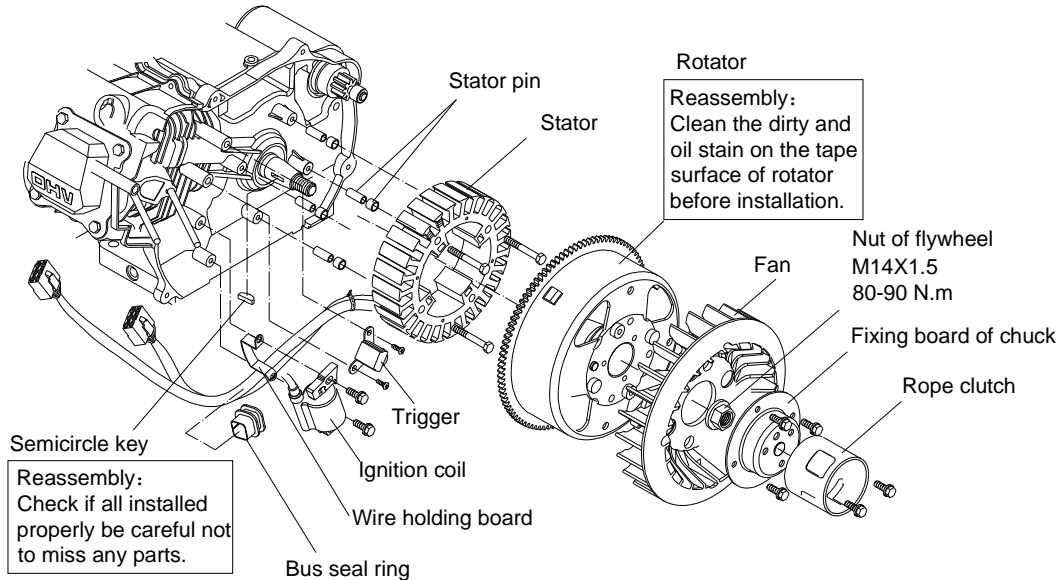

#### B. Inspection

##### (1) Ignition winding

Measure the resistance between green wire and olive wire

Resistance value	0.26~0.28 Ω
------------------	-------------

##### (2) Outer use charging winding

Measure the resistance between two blue wires.

Resistance value	0.12~0.15 Ω
------------------	-------------

##### (3) Built-in charging winding

Measure the resistance between two purple wires.

Resistance value	0.19~0.21 Ω
------------------	-------------

##### (4) Sub winding

Measure the resistance between two white wires.

Resistance value	0.12~0.14 Ω
------------------	-------------

##### (5) Main winding

Measure the resistance between three black wires.

Resistance value	120V	230/240V
	0.8~1.1 Ω	3.3~3.5 Ω

## 8.2 Ignition coil and trigger

### A. Disassembly and reassembly

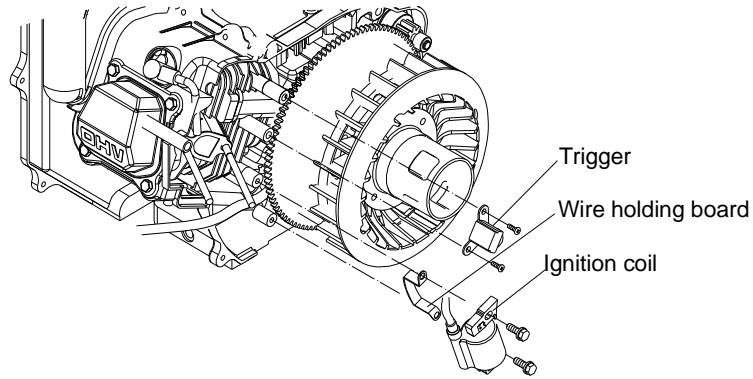

### B. Inspection

#### (1) Ignition coil

- With an ohmmeter check the resistance between the two wires going to the coil

primary resistance	0.8~1.3 Ω
--------------------	-----------

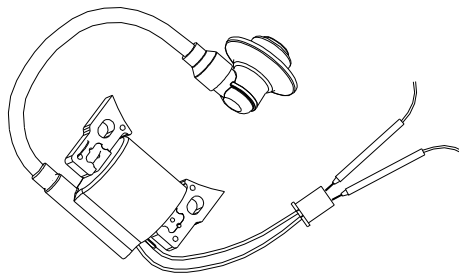

- Check resistance between one end of primary ignition coil terminals and spark plug cap to measure sub resistance of ignition coil.

Sub resistance	15~21K Ω
----------------	----------

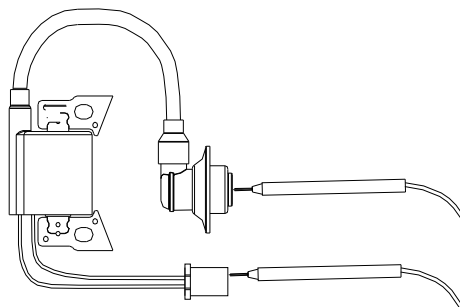

## (2) Trigger

Test the resistance between the trigger wires.

Resistance of trigger	80~130 $\Omega$
-----------------------	-----------------

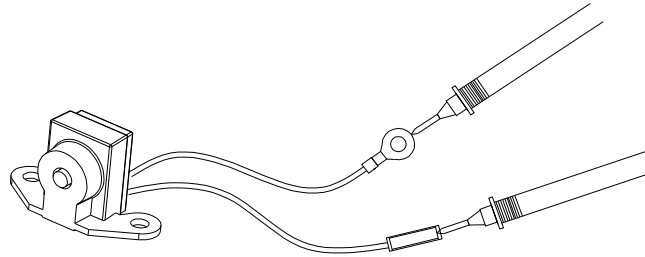

Adjustment:

Adjust the clearance between trigger and salient of the rotor.

clearance of trigger	0.020~0.030 in. (0.50~0.75mm)
----------------------	----------------------------------



Insert the gauge between the salient of the trigger and the rotor to measure the clearance. If it is not within the specified range, readjust the trigger to the recommended clearance.