

KIPOR

KIPOR POWER

OPERATION MANUAL

PLEASE READ THIS MANUAL CAREFULLY.
IT CONTAINS IMPORTANT SAFETY INFORMATION.

WWW.KIPOR.COM

KIPOR

KIPOR POWER CO., LTD.

11/F Suntime International Mansion, 450 Fushan Road,
Pudong, Shanghai, China
TEL: 86-21-58208881
FAX: 86-21-58208877
E-MAIL: kipor@kipor.com

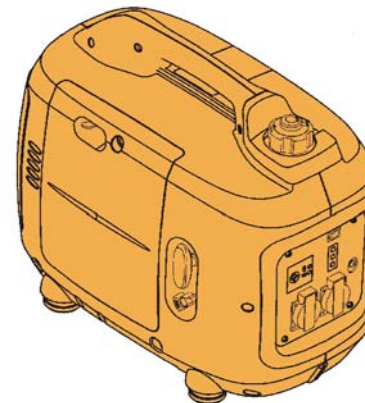

SINEMASTER
DIGITAL INVERTER GENERATOR

KGE2000Ti
KGE2000Tsi

Version 1, Printing date 22/08/2004

PREFACE

Thank you for purchasing our generators.

This manual covers operation and maintenance of the KGE2000Ti, KGE2000Tsi generator.

All information in this publication is based on the latest product information available at the time of approval for printing.

We reserve the right to make changes at any time without notice and without incurring any obligation.

No part of this publication may be reproduced without written permission.

This manual should be considered a permanent part of the generator and should remain with it if it is resold.

Pay special attention to statements preceded by the following words;



Indicates a strong possibility of severe personal injury or death if instructions are not followed.



Indicates a possibility of personal injury or equipment damage if instructions are not followed.

NOTE: Gives helpful information.

If a problem should arise, or if you have any questions about the generator, consult an authorized dealer.



The generators are designed to give safe and dependable service if operated according to instructions. Read and understand the Owner's Manual before operating the generator. Failure to do so could result in personal injury or equipment damage.

■ The illustration may vary according to the type.

CONTENTS

1. SAFETY INSTRUCTIONS	1
2. SAFETY LABEL LOCATIONS	3
3. COMPONENT IDENTIFICATION	5
4. PRE-OPERATION CHECK	9
5. STARTING THE ENGINE	13
High altitude operation	16
6. GENERATOR USE	17
7. STOPPING THE ENGINE	24
8. MAINTENANCE	26
9. TRANSPORTING/STORAGE	31
10. TROUBLESHOOTING	33
11. SPECIFICATIONS	35
12. ELECTRICAL WIRING DIAGRAM	36
13. LIGHT KIT	37

1. SAFETY INSTRUCTIONS

To ensure safe operation

WARNING



- The generators are designed to give safe and dependable service if operated according to instructions. Read and understand the Owner's Manual before operating the generator. Failure to do so could result in personal injury or equipment damage.

WARNING



- Exhaust gas contains poisonous carbon monoxide. Never run the generator in an enclosed area. Be sure to provide adequate ventilation.

WARNING



- The muffler becomes very hot during operation and remains hot for a while after stopping the engine. Be careful not to touch the muffler while it is hot. Let the engine cool before storing the generator indoors.
- The engine exhaust system will be heated during operation and remain hot immediately after stopping the engine. To prevent scalding, pay attention to the warning marks attached to the generator.

SAFETY INSTRUCTIONS

To ensure safe operation —

WARNING

- Gasoline is extremely flammable and explosive under certain conditions. Refuel in a well ventilated area with the engine stopped.
- Keep away from cigarette, smoke and sparks when refueling the generator, Always refuel in a well-ventilated location.
- Wipe up spilled gasoline at once.

WARNING

- Always make a pre-operation inspection (page 9) before you start the engine. You may prevent an accident or equipment damage.
- Place the generator at least 1m(3ft) away from buildings or other equipment during operation.
- Operate the generator on a level surface. if the generator is tilted, fuel spillage may result.
- Know how to stop the generator quickly and understand operation of all the controls. Never permit anyone to operate the generator without proper instructions.
- Keep children and pets away from the generator when it is in operation.
- Keep away from rotating parts while the generator is running.
- The generator is a potential source of electrical shocks when misused; do not operate with wet hands.
- Do not operate the generator in rain or snow and do not let it get wet.

2. SAFETY LABEL LOCATIONS

These labels warn you potential hazards that can cause serious injury. Read the labels and safety notes and precautions described in manual carefully.

If a label comes off or becomes hard to read, contact your dealer for a replacement.

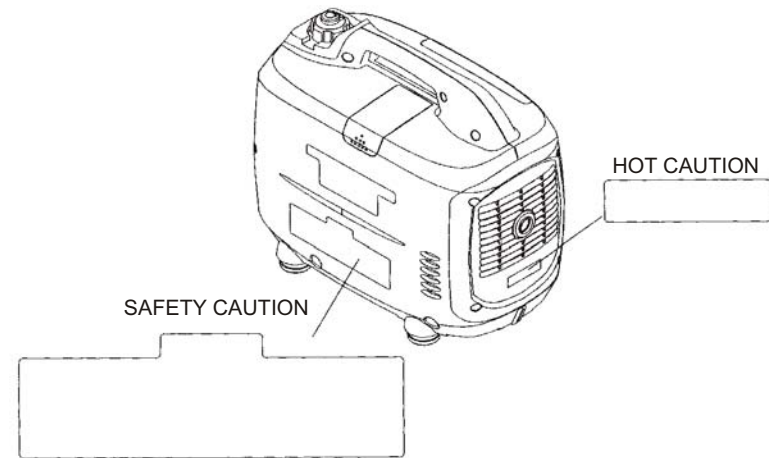
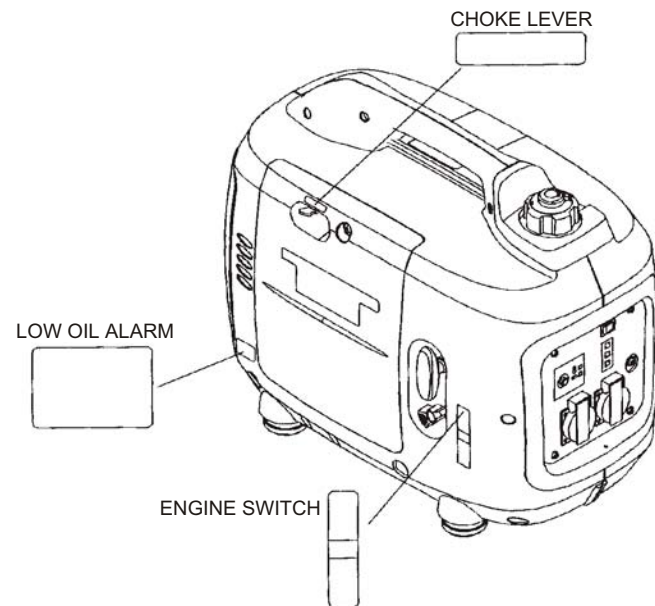

3. COMPONENT IDENTIFICATION

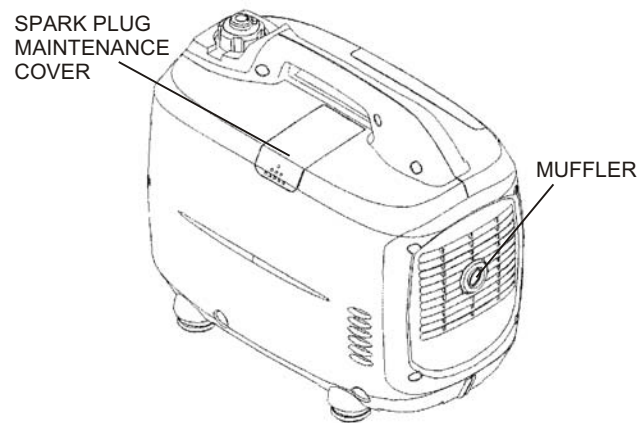
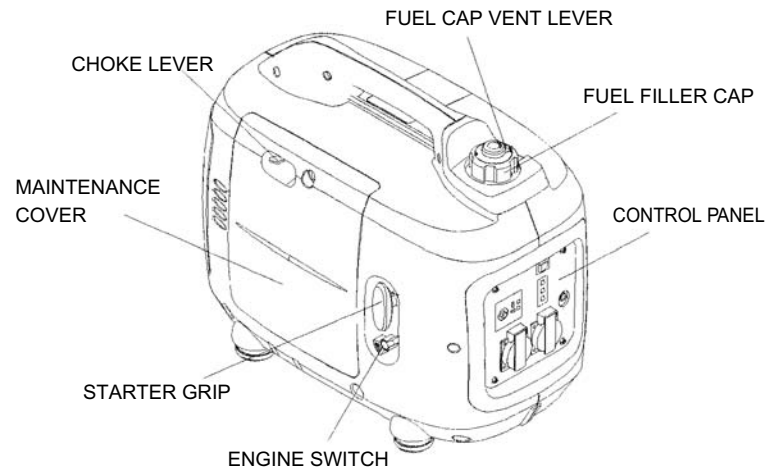

Control panel E type

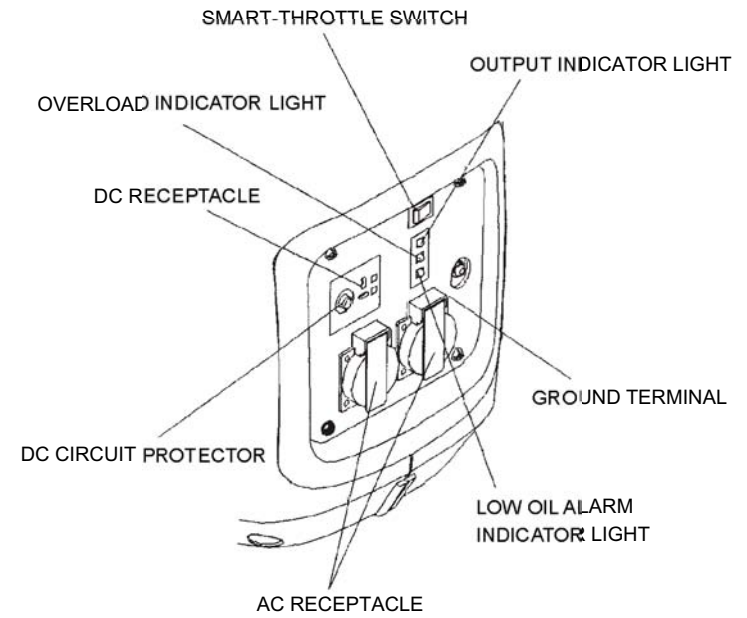

A type (120V)

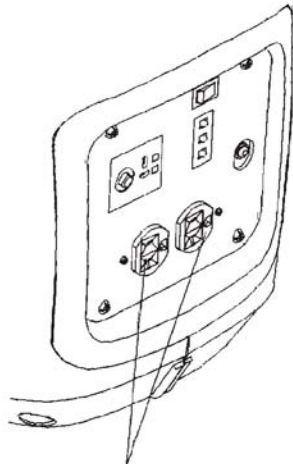

AC RECEPTACLE

Aus type

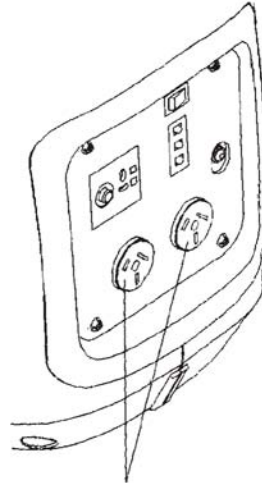

AC RECEPTACLE

H type

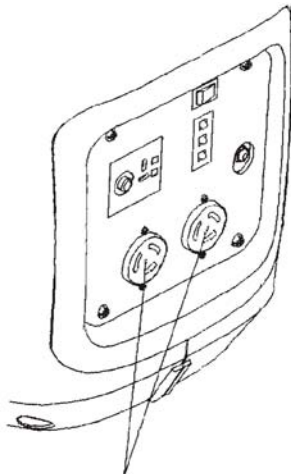

AC RECEPTACLE

A type (240V)

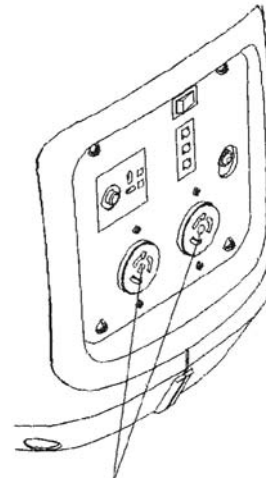

AC RECEPTACLE

Smart throttle

Engine speed is kept at idle automatically when the electrical appliance is disconnected and it returns to the proper speed to power of the electrical load when electrical appliance is connected. This position is recommended to minimize the fuel consumption while in operation.

⚠ WARNING

- Smart throttle system does not operate effectively, if the electrical appliance requires the momentary electric power.
- When high electrical loads are connected simultaneously, turn the Smart-throttle switch to the OFF position to reduce voltage vibration.
- In DC operation, turn the Smart-throttle switch to the OFF position.

OFF:

Smart-throttle system does not operate. Engine speed is kept over rated speed.

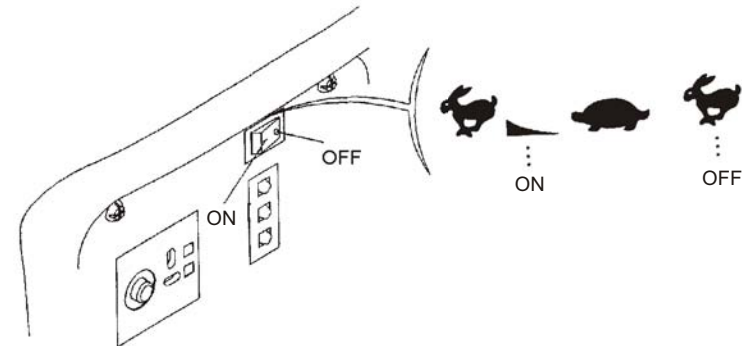

4. PRE-OPERATION CHECK

⚠ WARNING

- Be sure to check the generator on a level surface with the engine stopped.

1. Check the engine oil level.

⚠ WARNING

- Using nondetergent oil or 2-stroke engine oil could shorten the engine's service life.

Use high-detergent, premium quality 4-stroke engine oil, certified to meet or exceed U.S. automobile manufacturer's requirements for API Service Classification SG, SF. Select the appropriate viscosity for the average temperature in your area.

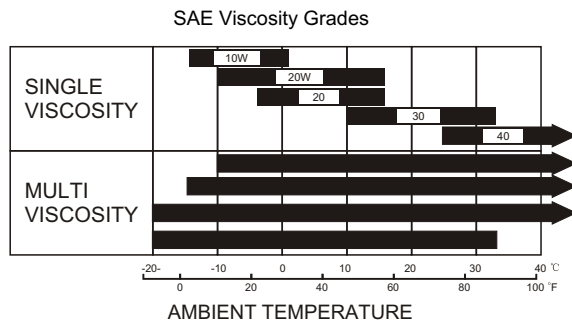

Loosen the cover screw and remove the left side maintenance cover. Remove the oil filler cap, and wipe the dipstick with a clean rag. Check the oil level by inserting the dipstick in the filler hole without screwing it in.

If the oil level is below the end of the dipstick, refill the recommended oil up to the top of the oil filler neck.

⚠ WARNING

- Running the engine with insufficient oil can cause serious engine damage.

NOTE: The Low Oil Alarm System will automatically stop the engine before the oil level falls below the safe limit. However, to avoid the inconvenience of an unexpected shutdown, it is still advisable to visually inspect the oil level regularly.

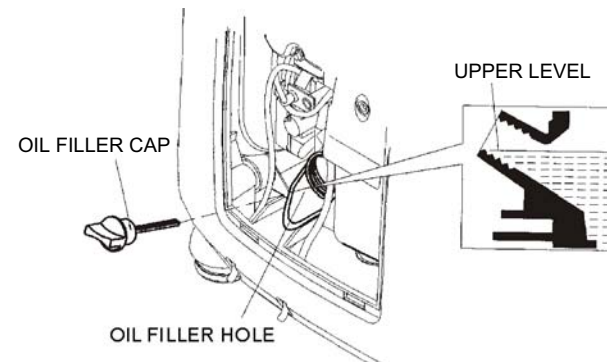

2. Check the fuel level.

Use automotive gasoline (Unleaded or lowleaded is preferred to minimize combustion chamber deposits).

If the fuel level is low, refuel the fuel tank until the level increased to the specified mark.

Never use an oil/gasoline mixture or dirty gasoline.

Avoid getting dirt, dust or water in the fuel tank.

After refueling, tighten the fuel filler cap securely.

⚠ WARNING

- Gasoline is extremely flammable and is explosive under certain conditions.
- Refuel in a well-ventilated area with the engine stopped. Do not smoke or allow flames or sparks in the area where the engine is refueled or where gasoline is stored.
- Do not overfill the fuel tank (there should be no fuel above the upper limit mark). After refueling, make sure the tank cap is closed properly and securely.
- Be careful not to spill fuel when refueling. Spilled fuel or fuel vapor may ignite. If any fuel is spilled, make sure the area is dry before starting the engine.
- Avoid repeated or prolonged contact with skin or breathing of vapor. KEEP OUT OF REACH OF CHILDREN.

Fuel tank capacity: 3.7 liter (0.97 US gal, 0.81 Imp gal)

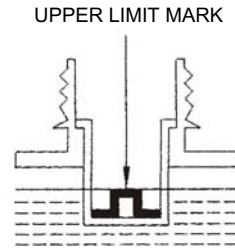
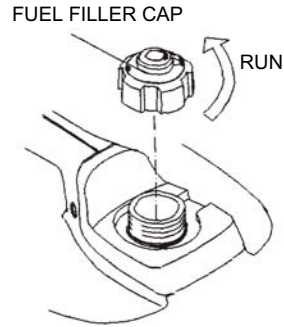

Gasolines containing alcohol

If you decide to use a gasoline containing alcohol (gasohol), be sure it's octane rating is at least as high as that recommended by us. There are two types of gasohol : one containing ethanol, and the other containing methanol. Do not use gasohol that contains more than 10% ethanol. Do not use gasoline containing methanol (methyl or wood alcohol) that does not also contain cosolvents and corrosion inhibitors for methanol. Never use gasoline containing more than 5% methanol, even if it has cosolvents and corrosion inhibitors.

NOTE

- Fuel system damage or engine performance problems resulting from the use of fuels that contain alcohol is not covered under the warranty. We cannot endorse the use of fuels containing methanol since evidence of their suitability is as yet incomplete.
- Before buying fuel from an unfamiliar station, try to find out if the fuel contains alcohol, if it does, confirm the type and percentage of alcohol used. If you notice any undesirable operating symptoms while using a gasoline that contains alcohol, or one that you think contains alcohol, replace it by a gasoline that you know does not contain alcohol.

3. Check the air cleaner.

Check the air cleaner element to be sure it is clean and in good condition.

Loosen the cover screw and remove the left side maintenance cover.

Press the latch tab on the top of the air cleaner body, remove the air cleaner cover, check the element. Clean or replace the element if necessary.

CAUTION

- Never run the engine without the air cleaner. Rapid engine wear will result from contaminants, such as dust and dirt, being drawn through the carburetor, into the engine.

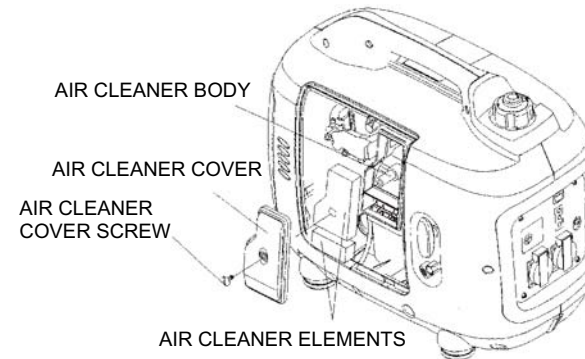
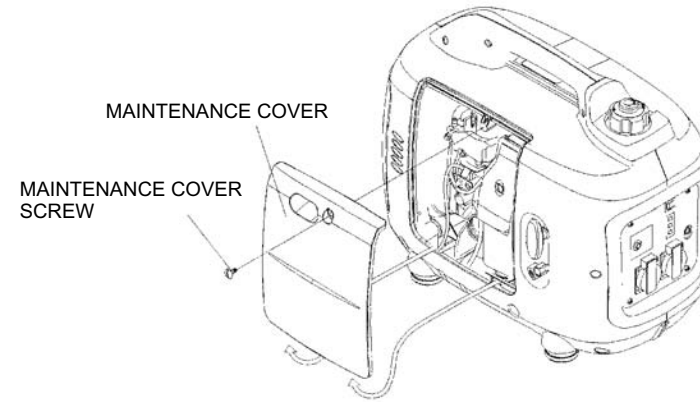

5. STARTING THE ENGINE

Before starting the engine, disconnect any load from the AC receptacle.

1. Turn the fuel cap lever fully clockwise to the ON position.

NOTE: Turn the fuel cap vent lever to the OFF position when transporting the generator.

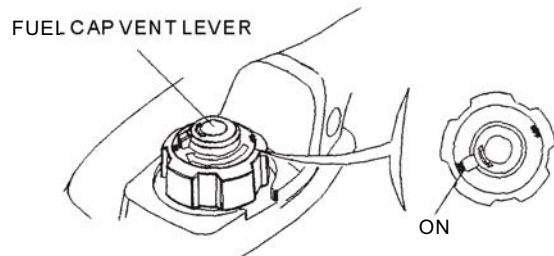

2. Turn the engine switch to the ON position.

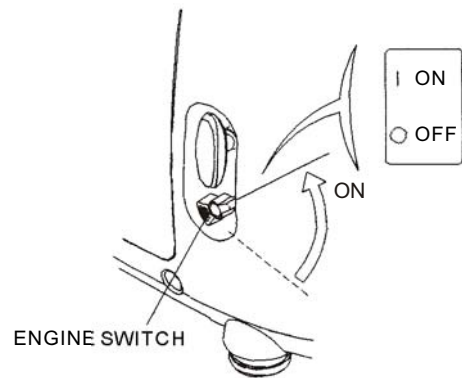

3. Move the choke lever to the START position.

NOTE:

Do not use the choke when the engine is warm or the air temperature is high.

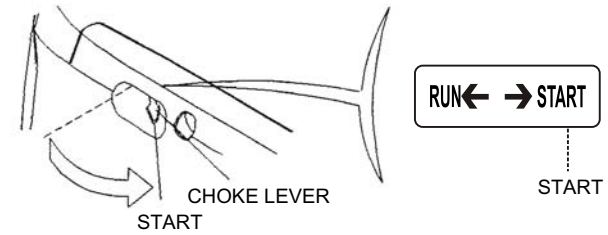

4. Pull the starter grip until resistance is felt, then pull the starter grip briskly toward the arrow as shown below.

⚠ CAUTION

■ Do not allow the starter grip to snap back, Return it slowly by hand.

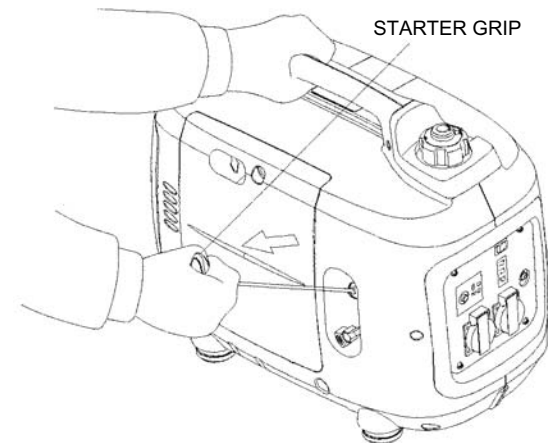

5. Move the choke lever to the RUN position after the engine warms up.

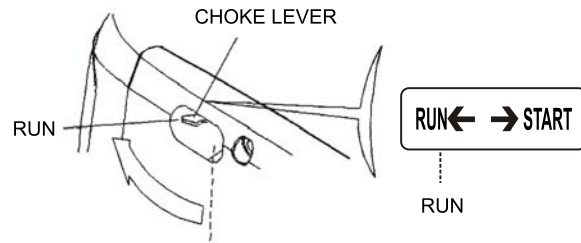

! NOTE

- If the engine stops and will not restart, check the engine oil level before troubleshooting in other areas.

High altitude operation

At high altitude, the standard carburetor air-fuel mixture will be excessively rich. Performance will decrease, and fuel consumption will increase.

High altitude performance can be improved by installing a smaller diameter main fuel jet in the carburetor and readjusting the pilot screws. If you always operate the generator at altitudes higher than 1,500 m (5,000 feet) above sea level, have your authorized dealer perform these carburetor modifications.

Even with suitable carburetor jetting, engine horsepower will decrease approximately 3.5% for each 300m (1,000 feet) increase in altitude. The affect of altitude on the horsepower will be greater than this if no carburetor modification is made.

! CAUTION

- Operation of the generator at an altitude lower than the carburetor is jetted for may result in reduced performance, overheating, and serious engine damage caused by an excessively lean air/fuel mixture.

6. GENERATOR USE

Be sure to ground the generator when the connected equipment is grounded.

⚠ WARNING

- To prevent electrical shock from faulty appliances, the generator should be grounded. Connect a length of heavy wire between the generator's ground terminal and an external ground source.
- Connections for standby power to a building's electrical system must be made by a qualified electrician and must comply with all applicable laws and electrical codes. Improper connections can allow electrical current from the generator to backfeed into the utility lines. Such backfeed may electrocute utility company workers or others who contact the lines during a power outage, and when utility power is restored, the generator may explode, burn, or cause fires in the building's electrical system.

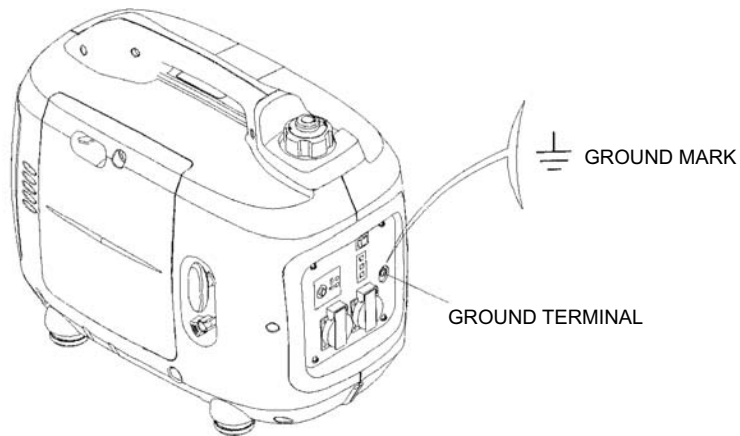

⚠ CAUTION

- Do not exceed the rated power.
The total wattage of all appliances connected must be considered.
- Do not exceed the current limit specified for any one receptacle.
- Do not connect the generator to a household circuit. This could cause the damage to the generator or to electrical appliances in the house.
- Do not modify or use the generator for other purpose than it is intended for. Also observe the following when using the generator.
- Do not connect an extension to exhaust pipe.
- When an extension cable is required, be sure to use a rubber sheathed flexible cable (IEC 245 or equivalent).
- Limit length of extension cables; 60m for cables of 1.5mm² and 100m for cables of 2.5mm². Long extension cables will reduce usable power due to resistance in the extension cable.
- Keep the generator away from other electric cables or wires such as commercial power supply lines.

⚠ NOTE

- The DC receptacle can be used while the AC power is in use. If you use both at the same time, be sure not to exceed the total power for AC and DC.
- Most appliance motors require more than their rated wattage for start-up.

AC applications

1. Start the engine and make sure only the output indicator light (green) comes on.
2. Confirm that the appliance to be used is switched off, and plug in the appliance.

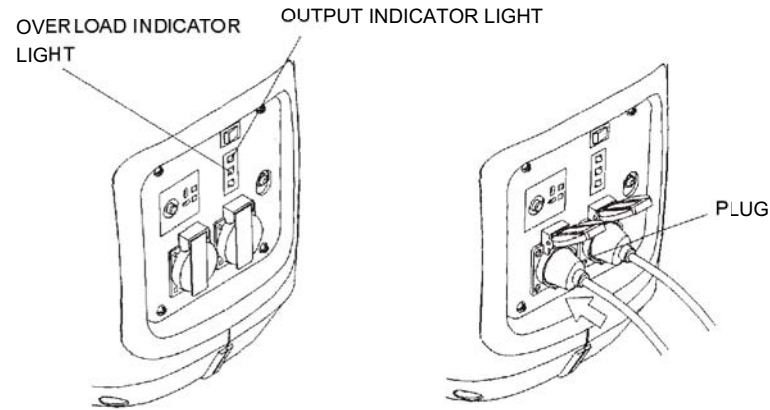

⚠ CAUTION

- Substantial overloading that continuously lights the overload indicator light (red) may damage the generator. Marginal overloading that temporarily lights the overload indicator light (red) may shorten the service life of the generator.
- Be sure that all appliances are in good working order before connecting them to the generator. If an appliance begins to operate abnormally, becomes sluggish, or stops suddenly, turn off the generator engine switch immediately. Then disconnect the appliance, and examine it for signs of malfunction.

3. In order to acquire both the best effect and the maximum service life of the generator. Usually, the new generator should run 20 hours under 50% load, the generator may reach the best performance.

Output and Overload Indicators

The output indicator light(green) will remain ON during normal operating conditions.

If the generator is overloaded (in excess of 1.6KVA), or if there is a short in the connected appliance, the output indicator light (green) will go OFF, the overload indicator light (red) will go ON and current to the connected appliance will be shut off.

Stop the engine if the overload indicator light (red) comes ON and investigate the overload source

■ Before connecting an appliance to the generator, check that it is in good order, and that its electrical rating does not exceed that of the generator. Then connect the power cord of the appliance, and start the engine.

OUTPUT INDICATOR LIGHT (GREEN) OVERLOAD INDICATOR LIGHT (RED)

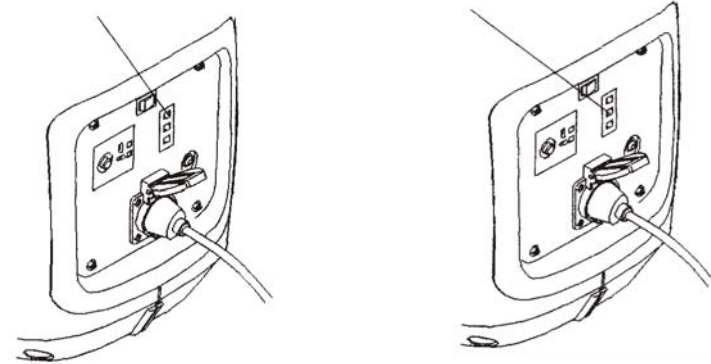

⚠ NOTE

- When an electric motor is started, both the overload indicator light (red) and the output indicator light (green) may go on simultaneously. This is normal if the overload indicator light (red) goes off after about four (4) seconds. If the overload indicator light (red) stays on, consult your generator dealer.

DC application

The DC receptacle may be used for charging 12 volt automotive-type batteries only, the zero load voltage is 15V-30V.

NOTE

- In DC operation, turn the Smart-throttle switch to the OFF position.

1. Connect the charging cables to the DC receptacle of the generator and then to the battery terminals.

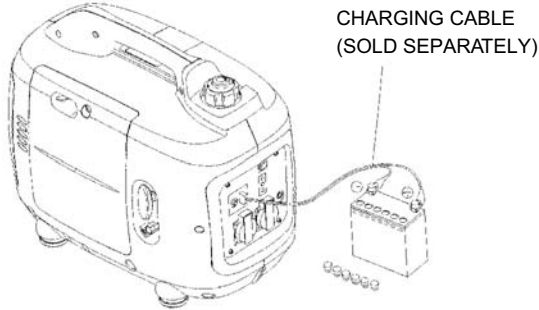

WARNING

- To prevent the possibility of creating a spark near the battery, connect charging cable first to the generator, then to the battery. Disconnect cable first at the battery.
- Before connecting charging cables to a battery that is installed in a vehicle, disconnect the vehicles grounded battery cable. Reconnect the vehicle's grounded battery cable after the charging cables are removed. This procedure will prevent the possibility of a short circuit and sparks if you make accidental contact between a battery terminal and the vehicle's frame or body.

CAUTION

- Do not attempt to start an automobile engine with the generator still connected to the battery. The generator may be damaged.
- Connect the positive battery terminal to the positive charging cord. Do not reverse the charging cables, or serious damage to the generator and/or battery may occur.

WARNING

- The battery gives off explosive gases; keep spark, flames and cigarettes away. Provide adequate ventilation when charging.
- The battery contains sulfuric acid (electrolyte). Contact with skin or eyes may cause severe burns. Wear protective clothing and a face shield.
 - If electrolyte gets on your skin, flush with water.
 - If electrolyte gets in your eyes, flush with water for at least 15 minutes and call a physician.
- Electrolyte is poisonous.
 - If swallowed, drink large quantities of water or milk and follow with milk of magnesia or vegetable oil and call a physician.
- KEEP OUT OF REACH OF CHILDREN.

2. Start the engine

NOTE

- The DC receptacle may be used while the AC power is in use.
- An overloaded DC circuit will trip the DC circuit protector. If this happens, wait a few minutes before pushing in the circuit protector to resume operation.

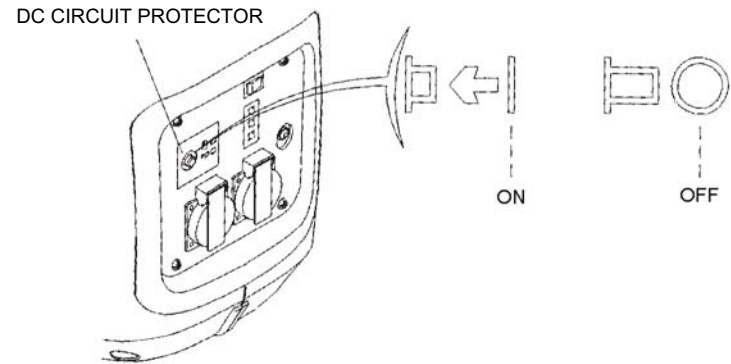

Low oil alarm system

The low oil alarm system is designed to prevent engine damage caused by an insufficient amount of oil in the crankcase. Before the oil level in the crankcase falls below a safe limit, the low oil alarm system will automatically shut down the engine (the engine switch will remain in the ON position).

If the low oil alarm system shuts down the engine, the low oil alarm indicator light (red) will come on when you operate the starter, and the engine will not run. If this occurs, add engine oil.

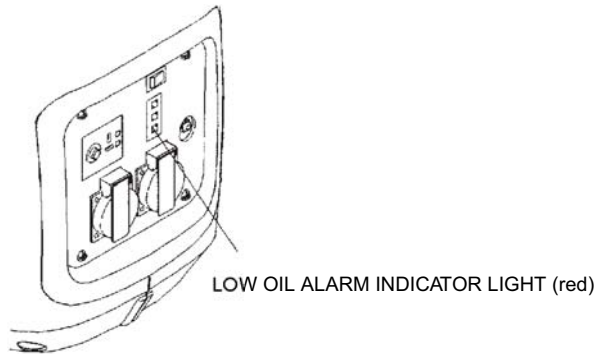

LOW OIL ALARM INDICATOR LIGHT (red)

7. STOPPING THE ENGINE

To stop the engine in an emergency, turn the engine switch to the OFF position.

IN NORMAL USE:

1. Switch off the connected equipment and pull the inserted plug out.

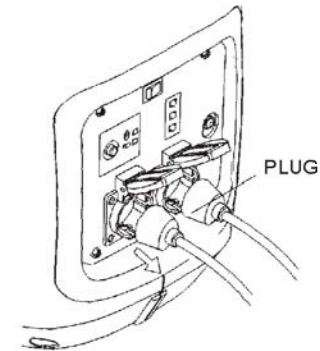

2. Turn the engine switch to the OFF position

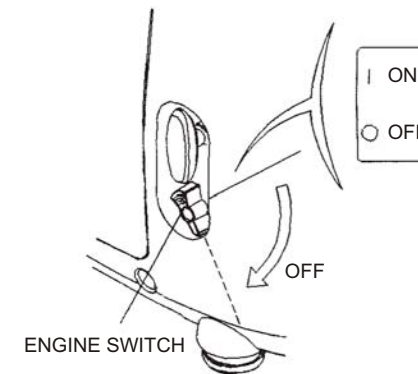

3. Allow the engine to cool well, and turn the fuel cap lever fully counterclockwise to the OFF position.

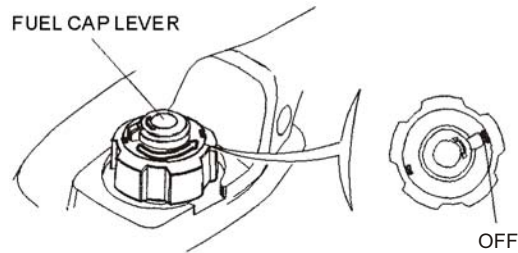

⚠ CAUTION

■ Be sure both the fuel cap lever, choke and the engine switch are in "OFF" position when stopping, transporting and/or storing the generator.

8. MAINTENANCE

The purpose of the maintenance and adjustment schedule is to keep the generator in the best operating condition.

Inspect or service as scheduled in the table below.

⚠ WARNING

■ Shut off the engine before performing any maintenance. If the engine must be run, make sure the area is well ventilated. The exhaust contains poisonous carbon monoxide gas.

⚠ CAUTION

■ Use genuine our parts or their equivalent. The use of replacement parts which are not of equivalent quality may damage the generator.

Maintenance Schedule

REGULAR SERVICE PERIOD(3) ITEM		EACH USE	FIRST MONTH OR 20HRS	EVERY 3 MONTHS OR 50HRS	EVERY 6 MONTHS OR 100 HRS	EVERY YEAR OR 200 HRS
Engine oil	Check level	○				
	Change		○		○	
Air cleaner	Check	○				
	Clean			○(1)		
Spark plug	Check-adjust				○	
	Replace					○
Combustion chamber	Clean	Every 300Hrs. (2)				
Valve clearance	Check-adjust					○(2)
Fuel tank and filter	Clean				○(2)	
Fuel line	Check	Every 2 years (Replace if necessary) (2)				

NOTE: (1) Service more frequently when used in dusty areas.

(2) These items should be serviced by your servicing dealer, unless you have the proper tools and are mechanically proficient. Refer to shop manual for service procedures.

(3) For commercial use, log hours of operation to determine proper maintenance intervals.

1. CHANGING OIL

Drain the oil while the engine is still warm to assure rapid and complete draining.

⚠ CAUTION

- Make sure to turn the engine switch and the fuel cap vent lever OFF before draining.

1. Loosen the cover screw and remove the left side maintenance cover.
2. Remove the oil filler cap.
3. Drain dirty oil into a container thoroughly.
4. Refill with the recommended oil, and check the oil level.
5. Reinstall the left side maintenance cover and tighten the cover screw securely.

Engine oil capacity: 0.4L (0.42USQT, 0.35LMQT)

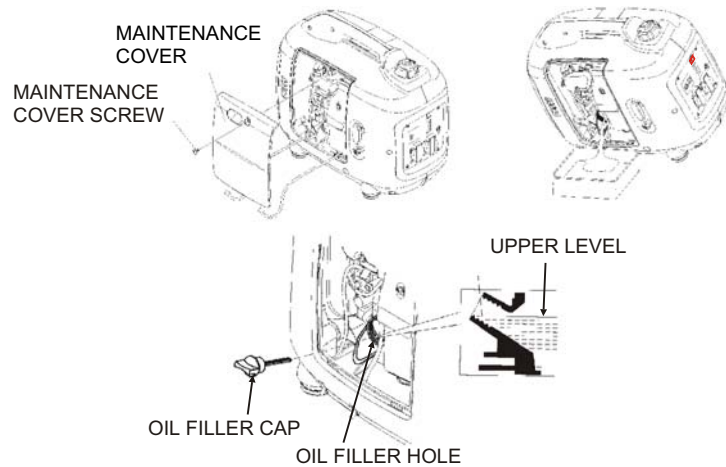

Wash your hands with soap and water after handling used oil.

⚠ NOTE

- Please dispose of used motor oil in a manner that is compatible with the environment. We suggest you take it in a sealed container to your local service station for reclamation. Do not throw it in the trash or pour it on the ground.

2. AIR CLEANER SERVICE

A dirty air cleaner will restrict air flow to the carburetor. To prevent carburetor malfunction, service the air cleaner regularly. Service more frequently when operating the generator in extremely dirty areas.

⚠ WARNING

- Do not use gasoline or low flash point solvents for cleaning. They are flammable and explosive under certain conditions.

⚠ CAUTION

- Never run the generator without the air cleaner, otherwise rapid engine wear may result.

1. Loosen the cover screw and remove the left side maintenance cover.
2. Remove the air cleaner cover.
3. Wash the element in a non-flammable or high flash point solvent and dry it thoroughly.
4. Soak the element in clean engine oil and squeeze out the excess oil.
5. Reinstall the main and outer air cleaner elements and the air cleaner cover. Tighten the cover screw securely.
6. Reinstall the maintenance cover and tighten the cover screw securely.

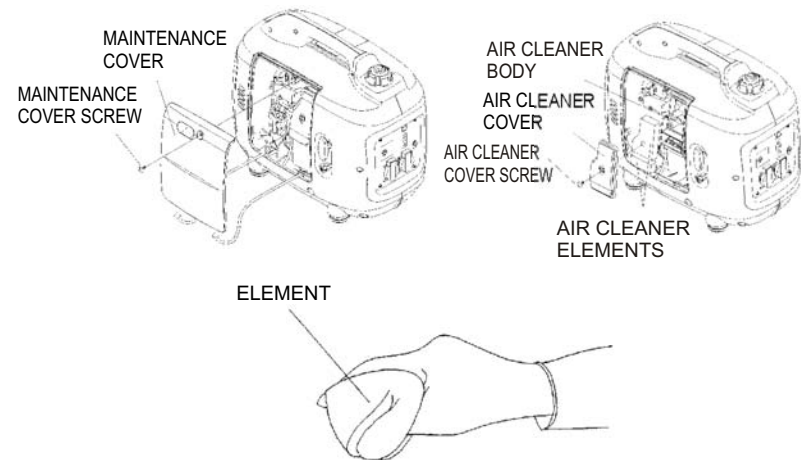

3. SPARK PLUG SERVICE

RECOMMENDED SPARK PLUG: A7RTC

To ensure proper engine operation, the spark plug must be properly gapped and free of deposits.

1. Remove the spark plug maintenance cover

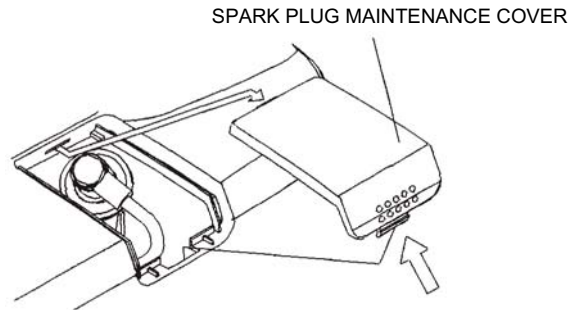

2. Remove the spark plug cap.
3. Clean any dirt from around the spark plug base.
4. Use the wrench to remove the spark plug.

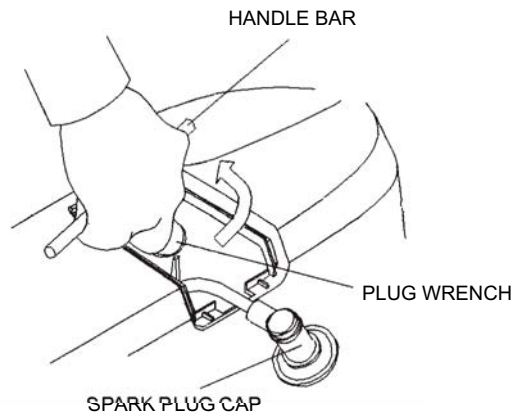

5. Visually inspect the spark plug. Discard it if the insulator is cracked or chipped.

Clean the spark plug with a wire brush if it is to be reused.

6. Measure the plug gap with a feeler gauge.

The gap should be 0.6~0.7mm (0.024-0.028in). Correct as necessary by carefully bending the side electrode.

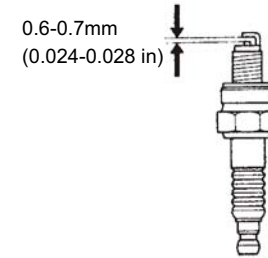

7. Install the spark plug carefully, by hand, to avoid cross-threading.
8. After a new spark plug has been seated by hand, it should be tightened 1/2 turn with a wrench to compress its washer.
- If a used plug is being reinstalled, it should only require 1/8 to 1/4 turn after being seated.
9. Reinstall the spark plug cap on the spark plug securely.
10. Reinstall the spark plug maintenance cover.

CAUTION

- The spark plug must be securely tightened. An improperly tightened plug can become very hot and possibly damage the generator.
- Never use a spark plug with an improper heat range.
- Never use a spark plug without damping resistance, or it will cause no AC output.

9. TRANSPORTING STORAGE

To prevent fuel spillage when transporting or during temporary storage, the generator should be secured upright in its normal operating position, with the engine switch OFF. The fuel cap vent lever is turned counterclockwise to the OFF position. Allow the engine to cool well before turning the fuel cap vent lever to the OFF position.

WARNING

When transporting the generator:

- Do not overfill the tank (there should be no fuel in the filler neck).
- Do not operate the generator while it is on a vehicle. Take the generator off the vehicle and use it in a well ventilated place.
- Avoid a place exposed to direct sunlight when putting the generator on a vehicle. If the generator is left in an enclosed vehicle for many hours, high temperature inside the vehicle could cause fuel to vaporize resulting in a possible explosion.
- Do not drive on a rough road for an extended period with the generator on board. If you must transport the generator on board, drain the fuel from the generator beforehand.

Before storing the unit for an extended period:

1. Be sure the storage area is free of excessive humidity and dust.
2. Drain the fuel.

WARNING

- Gasoline is extremely flammable and explosive under certain conditions.
- Do not smoke or allow flames or sparks in the area.

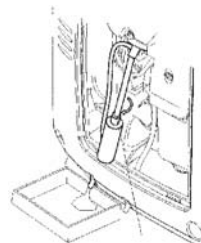

SCREW DRIVER

- a. Drain all gasoline from the fuel tank into an approved gasoline container.
- b. Turn the engine switch ON, and loosen the carburetor drain screw and drain the gasoline from the carburetor into a suitable container.
- c. With the drain screw loosened remove the spark plug cap, and pull the starter grip 3 to 4 times to drain the gasoline from the fuel pump.
- d. Turn the engine switch to the OFF position, and tighten the drain screw securely.
- e. Reinstall the spark plug cap on the spark plug securely.

3. Change the engine oil .
4. Remove the spark plug and pour about a tablespoon of clean engine oil into the cylinder. Crank the engine several revolutions to distribute the oil, then reinstall the spark plug.
5. Slowly pull the starter grip until resistance is felt. At this point, the piston is coming up on its compression stroke and both the intake and exhaust valves are closed. Storing the engine in this position will help to protect it from internal corrosion.

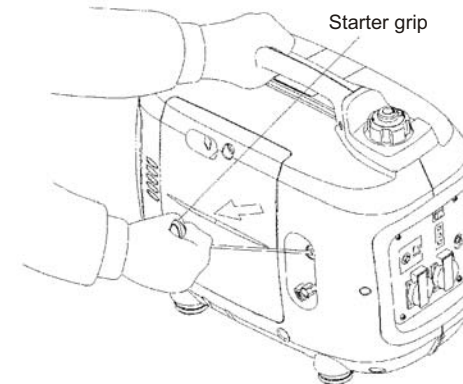

10. TROUBLESHOOTING

When the engine will not start:

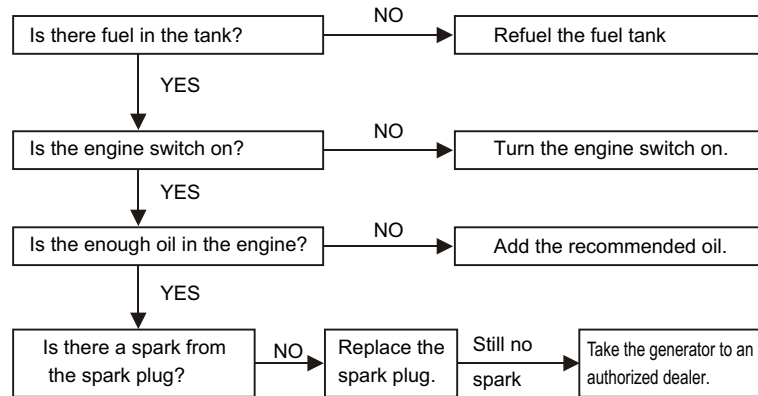

⚠ WARNING

- Be sure there is no spilled fuel around the spark plug. Spilled fuel may ignite.

If the engine still does not start, take the generator to an authorized dealer.

To check:

- 1) Remove the spark plug cap and clean any dirt from around the spark plug.
- 2) Remove the spark plug and install the spark plug in the plug cap.
- 3) Set the plug side electrode on the cylinder head to ground.
- 4) Pull the recoil starter, sparks should jump across the gap.

Appliance does not operate:

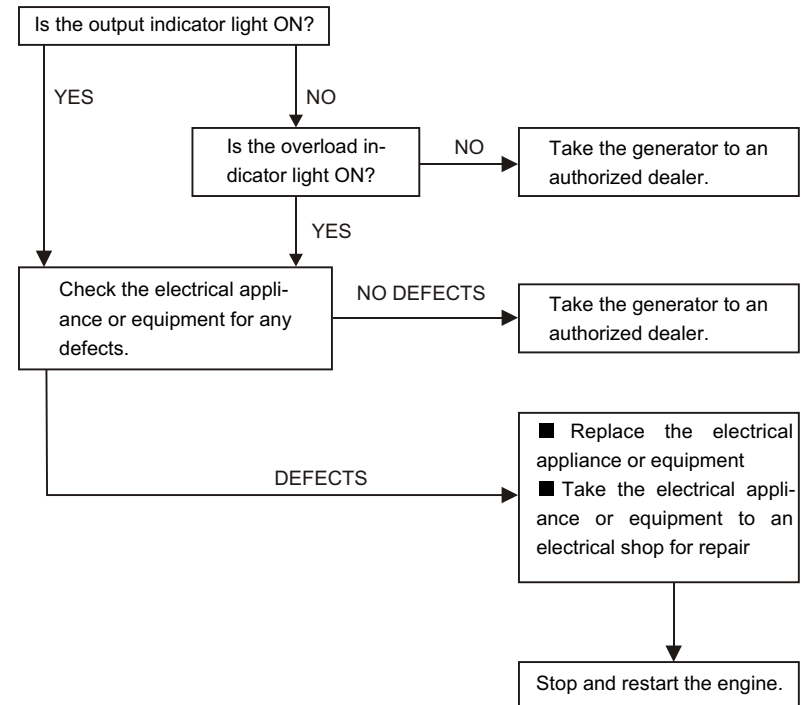

No electricity at the DC receptacle:

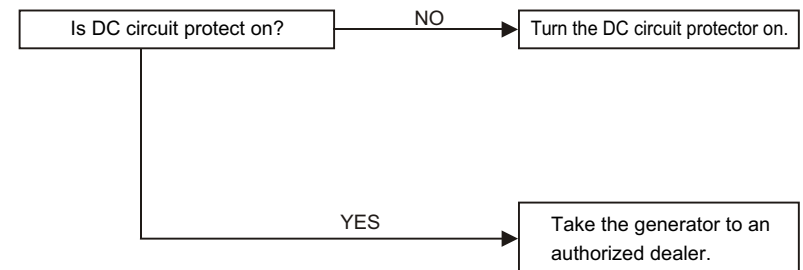

11. SPECIFICATIONS

SPECIFICATIONS

Model	KGE2000Ti/KGE2000Tsi		
Rated frequency (Hz)	50	60	60
Rated voltage (V)	230	120	240
Rated current (A)	7.0	13.3	6.7
Rated speed (rpm)	4500		
Rated output (kVA)	1.6		
Max output (kVA)	2.0		

DC output

DC voltage	12V-8.3A
Electric circuit breaker	Available
Phase number	Single phase

Engine

Model Type	KG105
Type	Single cylinder, 4 stroke, vertical, air-cooled, OHV, gasoline engine
Displacement (Bore × Stroke)	105ml (58 × 40mm)
Compression ratio	8.5:1
Rated power[kVA(Hp)/(r/min)]	2.2/4500
Rated rotation speed (rpm)	4500
Ignition system	T. C. I
Spark plug	A7RTC
Starting system	Recoil starter
Fuel	Automotive unleaded gasoline
Fuel consumption (g /kW·h)	630
Lube oil	SAE 10W30 (above CC grade)

Fuel tank capacity (L)	3.7
Continuous running time (hr) (at rated output)	4.0
Noise level(zero load~ full load) [dB(A)/7m]	54 – 59
Overall dimension (L × W × H) [mm(in)]	Ti: 549 × 291 × 405(21.61 × 11.46 × 15.94) Tsi: 660 × 296 × 431(25.98 × 11.65 × 16.97)
Dry weight [kg(lbs)]	Ti: 22 (48.4) Tsi: 23.5 (51.7)

12. ELECTRICAL WIRING DIAGRAM

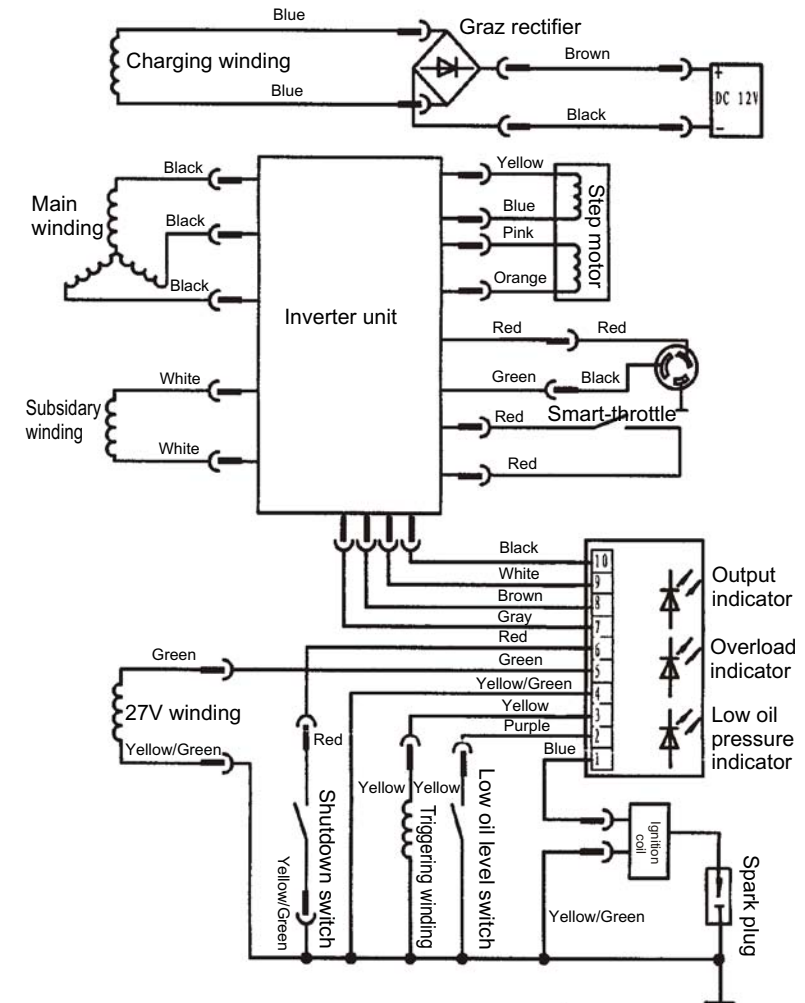

13. LIGHT KIT

MOUNTING INSTRUCTIONS FOR: KGE2000Tsi LIGHT KIT

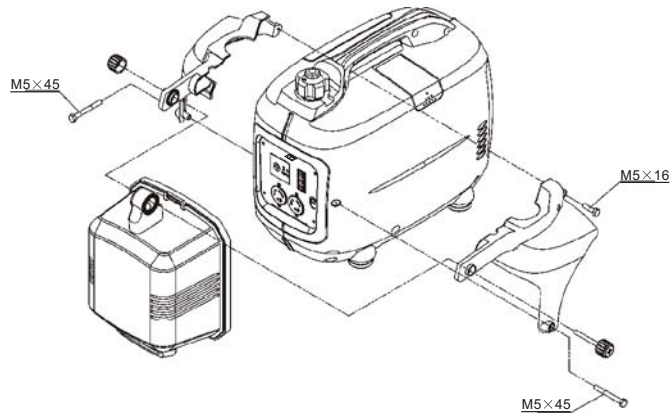

Our KGE2000Tsi Light kit is designed specifically for use on KGE2000Ti Generator.

Tools required: Phillips Screwdriver

Fittings supplied:

- (1) KGE2000Ti Portable Digital Generator
- (2) KGE2000Tsi-05100 Light Kit Assembly
- (3) KGE2000Tsi-05001 Antiskid Round Nut
- (4) KGE2000Tsi-05001 Antiskid Round Stud
- (5) KGE2000Tsi-05003 Left Mount Plate of Light Kit
- (6) KGE2000Tsi-05004 Right Mount Plate of Light Kit
- (7) Screw M5×45 2PCS
- (8) Screw M5×16 1PCS

This is where the Light Kit will be mounted, see KGE2000Tsi Assembly Drawing of the Portable Digital Generator Light Kit.

- (1) Remove the screw from the KGE2000Ti Portable Digital Generator and the screws from the side of the control plate;
- (2) Disperse the mount plate of the Light, use screw M5×45 and screw M5×16, then locate the mount plate of Light Kit on generator. **DO NOT TIGHTEN SCREWS.**
- (3) Use the antiskid round stud through the Light, left and right mount plate in turn, then lock the antiskid round stud.
- (4) After adjusting the turnover angular of Light, tighten the above mentioned of antiskid round stud, screw M5×45 and screw M5×16 in turn.

Before energizing the light, be sure to read the Generator Owner's Manual for best operation and maintenance information, along with the safety precautions. It is recommended that the light switch be in the OFF position when starting the generator.