

WWW.KIPOR.COM

KIPOR

**KIPOR POWER
SHOP MANUAL**

PLEASE READ THIS MANUAL CAREFULLY.
IT CONTAINS IMPORTANT SAFETY INFORMATION.

KIPOR

KIPOR POWER CO., LTD.

11/F Suntime International Mansion, 450 Fushan Road,
Pudong, Shanghai, China
TEL: 86-21-58208881
FAX: 86-21-58208877
E-MAIL: kipor@kipor.com

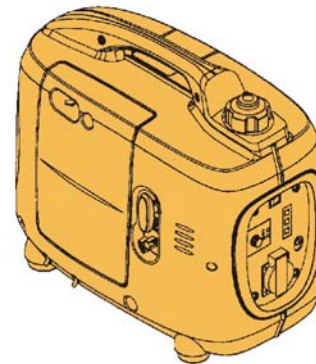

SINE MASTER

KGE1000Ti

Version 2, Printing date 25/06/2005

Preface

This manual covers the construction, function and servicing procedure of our KGE1000Ti generators.

Careful observance of these instructions will result in better, safe service work.

All information, illustrations, directions and specifications included in this publication are based on the latest product information available at the time of approval for printing. We reserve the right to make changes without incurring any obligation whatever. No part of this publication may be reproduced without written permission.

CONTENTS

1. Specifications	1
1.1 Specifications	1
1.2 Characteristics	2
1.3 Performance curves	3
1.4 Dimensional drawings	4
1.5 Wiring diagram	5
2. Service informations	6
2.1 The importance of proper service	6
2.2 Important safety precacutions	6
2.3 Service rules	7
2.4 Serial number location	8
2.5 Maintenance standards	9
2.6 Torque values	11
2.7 Troubleshooting	13
2.8 Cable/harness routing	24
3. Maintenance	26
3.1 Maintenance schedule	26
3.2 Low oil alarm	26
3.3 Engine oil	27
3.4 Air cleaner	28
3.5 Spark plug	29
3.6 Valve clearance	30
3.7 Fuel tank/fuel filter	32
3.8 Fuel tube/fuel pump	32

4. Muffler	34
4.1 Muffler	34
5. Carburetor	35
5.1 Carburetor	35
6. Control panel	40
6.1 Control panel	40
7. Side covers/Fuel tank/Inverter unit	44
7.1 Side cover	44
7.2 Fuel tank	48
7.3 Inverter unit/Engine bed	49
8. Recoil starter/Fan cover	50
8.1 Recoil starter/Fan cover.....	50
8.2 Fan shroud	54
8.3 Exhaust manifold/Carburetor insulator	55
9. Generator	56
9.1 Generator	56
10. Camshaft/Rocker arm	60
10.1 Rocker arm/Push rod	60
10.2 Crankcase side cover/camshaft/valve lifter	61
10.3 Inspection	63
11. Oil case/Crankshaft/Cylinder block/Piston/valve	65
11.1 Oil case/Crankshaft	65
11.2 Piston	68
11.3 Valve/Cylinder block	69
11.4 Inspection	70

■ Valve stem O.D.

Inspect each valve face for pitting or wear irregularities.

Inspect each valve stem for bending or abnormal stem wear.

Insert the valve into the valve guide and check for operation.

Measure the valve stem O.D. at the sliding surface of the valve guide.

	Standard	Service limit
IN	3.970-3.985mm (0.15623-0.1569in)	3.900mm (0.1535in)
EX	3.935mm (0.1549-0.1555in)	3.880mm (0.1528in)

■ Valve guide I.D

	Standard	Service limit
IN	4.000-4.018mm (0.1575-0.1528in)	4.060mm (0.1598in)

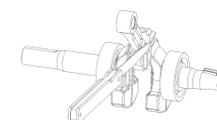

If the measurement exceeds the service limit, replace the cylinder barrel.

■ Valve stem to guide clearance

	Standard	Service limit
IN	0.015-0.048mm (0.0006-0.0019in)	0.098mm (0.0039in)
EX	0.050-0.083mm (0.0020-0.0033in)	0.098mm (0.0039in)

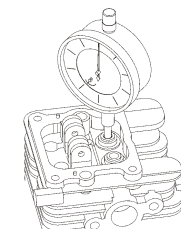

Oil level switch

Check for continuity between the oil level switch's yellow lead wire and the ground terminal (green lead).

(1) The oil level switch is normal if there is no continuity with the switch upside down.

(2) There must be continuity between the wires with the switch of the straight side up.

(3) Suspend the switch in a container filled with oil and check the float operation. The switch is normal if there is continuity between the wires initially and no continuity when the switch is soaked in the oil.

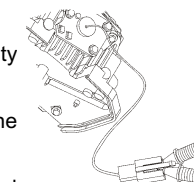

■ Connecting rod big end oil clearance

- (1) Clean the crank pin and the connecting rod big end.
- (2) Set a plastic gauge on the crank pin. Install the connecting rod cap and tighten the connecting rod bolt to the specified torque.

Torque: 6.0N m (0.6kgf.m, 4.3lbf.ft)

Note:

Set the plastic gauge in the axial direction on the crank pin.

Hold the crankshaft not to turn when tightening the bolt.

- (3) Remove the connecting rod cap and measure the plastic gauge with the plastic gauge scale.

Standard	Service limit
9.994-10.000mm (0.3935-0.3937in)	9.950mm (0.3917in)

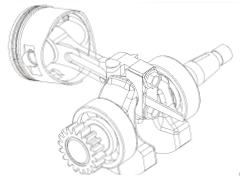

- (4) If the measurement exceeds the service limit, replace the connecting rod and recheck the clearance. If the clearance, measured by using a new connecting rod, exceeds the service limit, replace the crankshaft.

■ Connecting rod big end side clearance

Measure the clearance using a feeler gauge.

Standard	Service limit
0.1-0.6mm (0.004-0.024in)	0.8mm (0.031in)

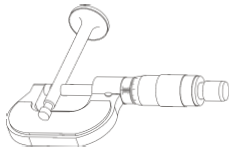

■ Valve spring free length

Standard	Service limit
23.7mm (0.93in)	22.8mm (0.90in)

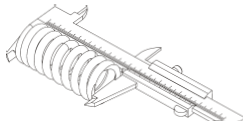

1. SPECIFICATIONS

1.1 SPECIFICATIONS

Dimensions and weights

Model	KGE1000Ti
Overall length	460mm
Overall width	248mm
Overall height	395mm
Dry weight	14kg

Engine

Model	KG55
Type	4-stroke, overhead valve, single cylinder
Displacement	53.5ml
Bore x stroke	43.5 x 36mm
Maximum horsepower(KVA)	1.3/5500
Compression ratio	8.5:1
Cooling system	Forced air
Ignition system	T.C.I
Ignition timing	30° B.T.D.C
Spark plug	A7RTC
Carburetor	Float type, Horizontal, butterfly valve type
Air cleaner	Semi-dry type
Governor	Electronic control type
Lubrication system	Forced splash
Oil capacity	0.25L
Starting system	Recoil starter
Stopping system	Primary circuit ground
Fuel used	Automotive unleaded gasoline

Generator

Model	KD10
Generator type	Multi pole rotation type
Generator structure	Self-ventilation drip-proof type
Excitation	Self-excitation (Magnet type)
Voltage regulation system	PWM(Plush width modulation)
Phase	Single phase
Rotating direction	Clockwise (Viewed from the generator)
Frequency regulation	AC-DC-AC conversion (Inverter type)

1.2 CHARACTERISTICS

Mode	KGE1000Ti					
Maximum output	1.0KVA					
Rated output	AC	0.9KVA				
	DC	96W				
Rated frequency	60Hz	50Hz	60Hz	50Hz	50Hz	
Rated voltage	AC	120V	230V	220V	240V	220V
	DC	12V				
Rated current	AC	7.5A	3.9A	4.1A	3.8A	4.1A
	DC	8.3A				
Power factor(cos φ)	1.0					
Voltage variation rate	Momentary	10%max.				
	Average	1.5%max.				
	Average time	3 sec. Max.				
Voltage stability	± 1%					
Frequency variation rate	Momentary	1%max.				
	Average	1%max.				
	Average time	1 sec. Max.				
Frequency stability	± 0.1%					

■Piston ring end cap

Use the top of the piston to piston the ring horizontally in the cylinder, and measure the piston ring end gap.

	Standard	Service limit
Top/Second	0.150-0.300mm (0.0059-0.018in)	0.600mm (0.0236in)

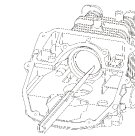

■Piston pin O.D.

Standard	Service limit
9.994-10.000mm (0.3935-0.3937in)	9.950mm (0.3917in)

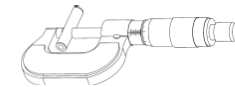

■Piston pin bore I.D.

Standard	Service limit
10.002-10.008mm (0.3938-0.3940in)	10.050mm (0.3957in)

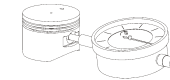

■Connecting rod small end I.D.

Standard	Service limit
10.006-10.017mm (0.3939-0.3944in)	10.050mm (0.3957in)

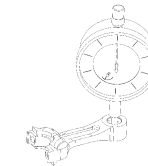

■Connecting rod big end I.D.

Standard	Service limit
15.000-15.011mm (0.5906-0.5910in)	15.040mm (0.5921in)

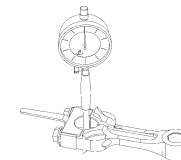

■Crank pin O.D.

Standard	Service limit
14.973-14.984mm (0.5985-0.5989in)	14.940mm (0.5882in)

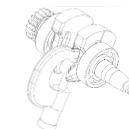

11.4 Inspection

Piston skirt O.D.

Measure and record the piston O.D. at a point 10mm from the bottom of the skirt and 90° to the piston pin bore.

Standard	Service limit
41.770-41.790mm	41.700mm



Cylinder sleeve I.D.

Measure and record the cylinder I.D. at three levels in both X axis (parallel to piston pin) and the Y axis (perpendicular to piston pin). Take the maximum reading of each measurement to determine the cylinder I.D.

Standard	Service limit
41.800-41.815mm	41.900mm

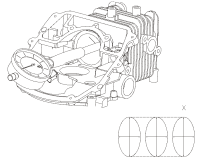

Piston pin to Cylinder clearance

Standard	Service limit
0.010-0.045mm (0.0004-0.0018in)	0.120mm (0.0047in)

Piston ring width

	Standard	Service limit
Top	0.77-0.79mm	0.72mm
Second	0.97-0.99mm	0.920mm

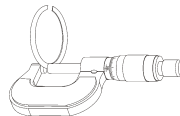

Ring side clearance

	Standard	Service limit
Top/Second	0.015-0.050mm	0.120mm

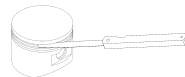

Insulation resistance	10MΩ min	
AC circuit protector	9.4A	4.9A
DC circuit protector	10A	
Fuel tank capacity	2.6L	
Fuel consumption	0.58L/Hr	
(at rated load)	0.62L/Hr	
Operating hours (at rated load without refueling)	approx 3.9Hr *3.6Hr	
Noise level	54-59dB(A)/7m	

1.3 PERFORMANCE CURVES

The curves show performance of the generator under average condition.

Performance may vary to some degree depending on ambient temperature and humidity.

The output voltage will be higher than usual when the generator is still cold, immediately after the engine starts.

AC External characteristic curves

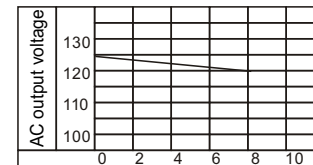

AC load current

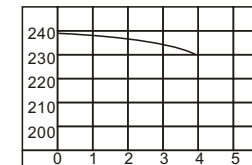

AC load current

DC External characteristic curves

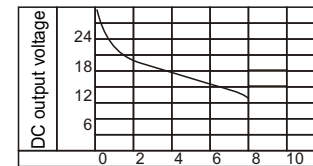

DC load current

1.4 DIMENSIONAL DRAWING

Unit: mm(in)

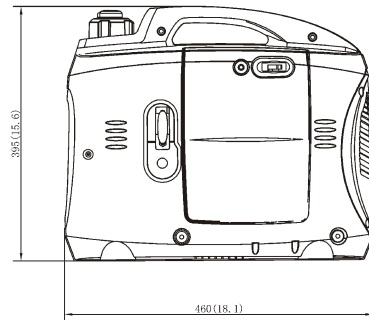
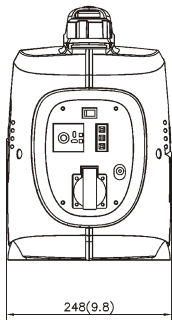
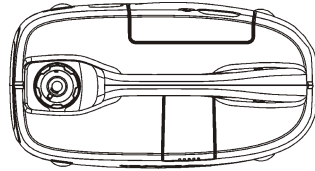

11.3 Valve/Cylinder block

a. Disassembly/Reassembly

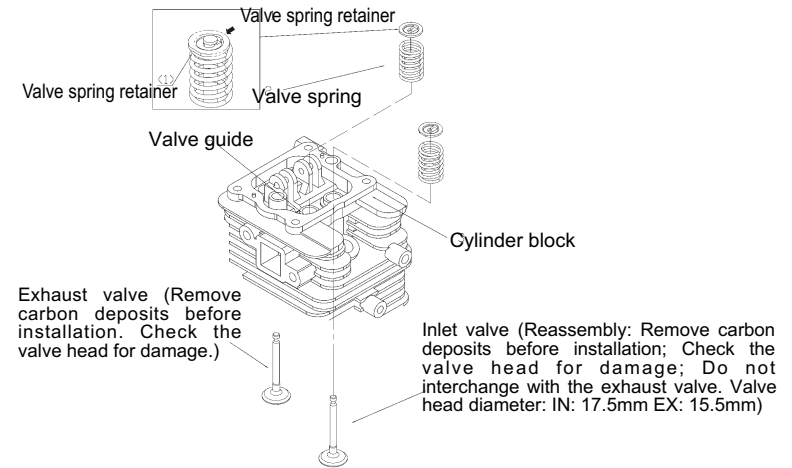

Combustion chamber cleaning

(1) Prepare a protective lining of thick paper or equivalent material, with a diameter large enough to fit against the inner wall of the cylinder, and insert it into the cylinder.

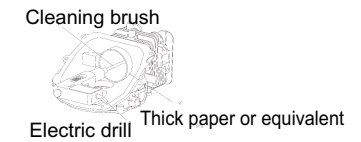

(2) Attach a cleaning brush to an electric drill and clean the combustion chamber.



Be sure to insert a thick paper into the cylinder to protect the inner wall of the cylinder during cleaning.

Do not press the cleaning brush with force against the combustion chamber.

11.2 Piston

Disassembly/Reassembly

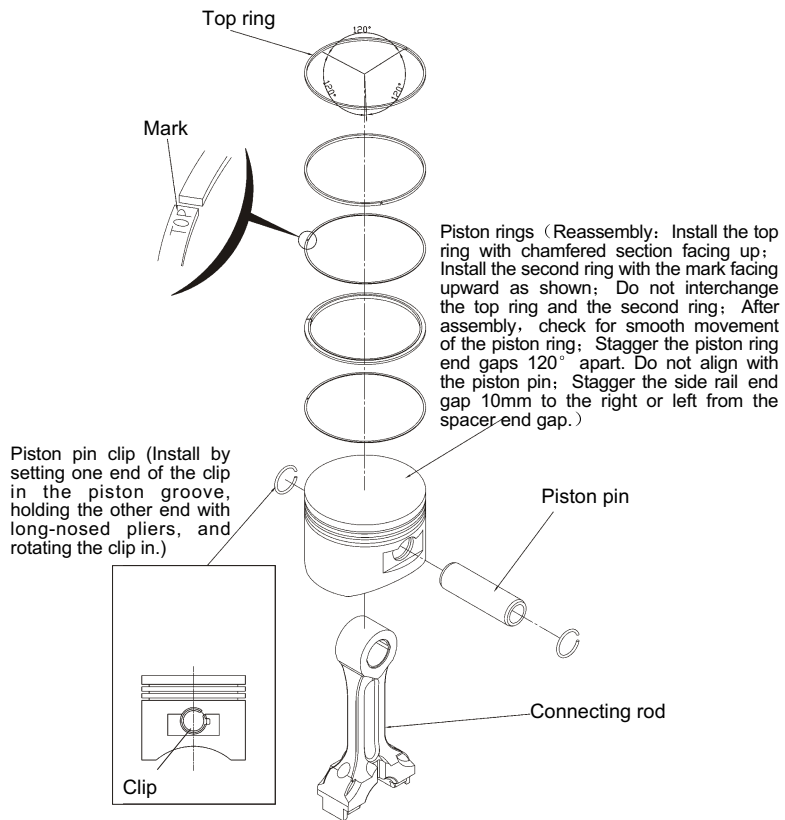

1.5 WIRING DIAGRAM

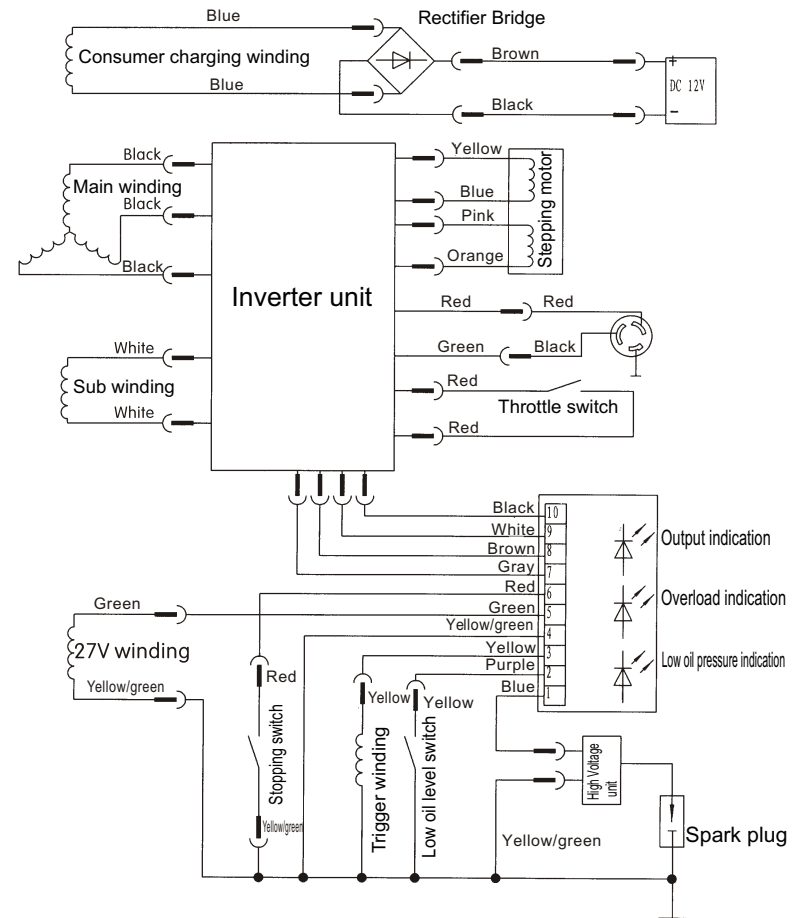

Wiring diagram KGE1000Ti-13000J

2. Service information

2.1 The importance of proper servicing

■ Proper servicing is essential to the safety of the operator and the reliability of the engine. Any error or oversight made by the technician while servicing can easily result in faulty operation, damage to the engine or injury to the operator.



■ Improper servicing can cause an unsafe condition that can lead to serious injury or death.

Follow the procedures and precautions in this shop manual carefully.

■ Some of the most important precautions are given below. However, we cannot warn you of every conceivable hazard that can arise in performing maintenance or repairs. Only you can decide whether or not you should perform a given task.



■ Failure to follow maintenance instructions and precautions can cause you to be seriously hurt or killed. Follow the procedures and precautions in this shop manual carefully.

2.2 Important safety precautions

Be sure you have a clear understanding of all basic shop safety practices and that you are wearing appropriate clothing and safety equipment. When performing maintenance or repairs, be especially careful of the following:

■ Read the instructions before you begin, and be sure you have the tools and skills required to perform the tasks safely.

■ Be sure that the engine is off before you begin any maintenance or repairs. This will reduce the possibility of several hazards:

Carbon monoxide poisoning from engine exhaust:

Be sure there is adequate ventilation whenever you run the engine.

Burns from hot parts:

Let the engine cool before you touch it.

Injury from moving parts:

Do not run the engine unless the instruction tells you to do so. Even then, keep your hands, fingers, and clothing away.

■ To reduce the possibility of a fire or explosion, be sure when working around gasoline. Use only a nonflammable solvent, not gasoline, to clean parts. Keep all cigarettes, sparks, and flames away from all fuel-related parts.

■ Breather valve installation

- 1) Clean the oil outlet valve, stopper plate and the valve installation section of the cylinder block.
- 2) Install the valve aligning the positioning projection and chamfer of the valve with the groove and chamfer of the cylinder block.
- 3) Install the stopper plate on the valve aligning the chamfered corner of the stopper plate with the chamfer of the cylinder block.
- 4) Tighten the 3mm screw securely.

■ Connecting rod cap

Install by aligning the alignment marks on the connecting rod big end and on the cap.

Install with the oil dipper facing the flywheel installation side.

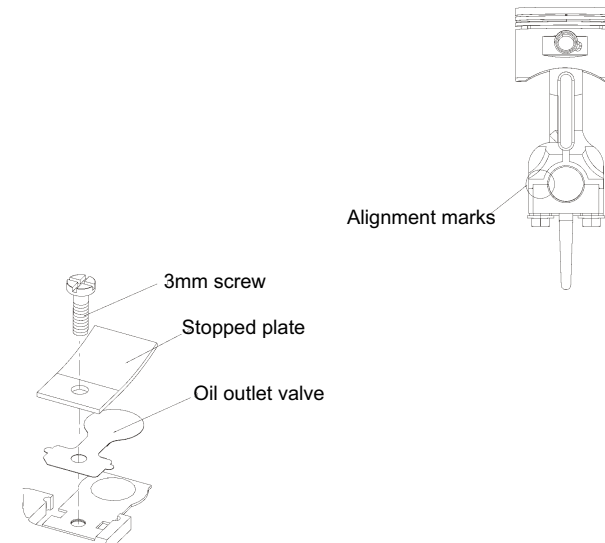

■ Oil case assembly

(1) Clean the mating surfaces of the oil case and the cylinder block with a degreasing cleaning agent or a clean shop towel.

(2) Tighten the two 6X15 mm dowel pins against the cylinder block.

(3) Apply the stick 1.5 to 2.0 mm in diameter of the liquid packing (Three bond 1216E or equivalent) to the mating surface of the cylinder block as shown)

(4) Install the crankcase cover on the cylinder block.

Note:

Assemble the oil case with the cylinder block within 3 minutes after application of the liquid packing.

If it is hard to install the oil case properly, install by turning the crankshaft a little.

Take care not to damage the oil seal lip.

5) Loosely tighten the bolts, and then tighten them to the specified torque in the numbered sequence shown.

Torque: 7.5N m (0.75kgf.m, 5.4lbf.ft)

Wait for 30 minutes after assembly. Do not add oil or start the engine during this period.

■ Oil seal installation

Drive in the oil seal to the depth shown using the special tools.

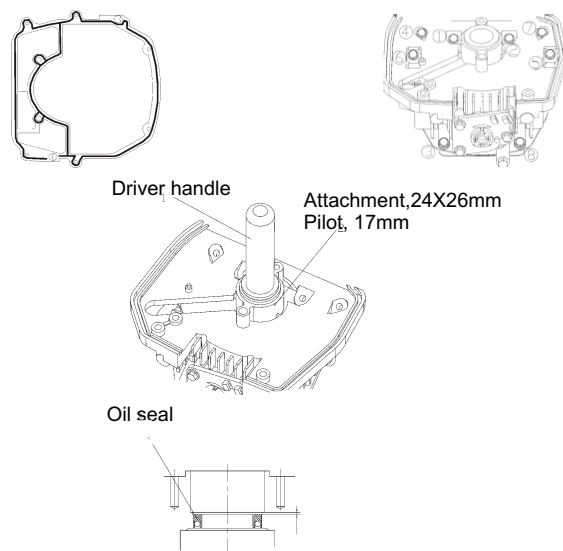

2.3 Service rules

1. Use genuine or recommended parts and lubricants or their equivalents. Parts that do not meet our design specifications may damage the engine.

2. Use the special tools designed for the product.

3. Install new gaskets, O-rings, etc. when reassembling.

4. When torquing bolts or nuts, begin with larger-diameter or inner bolts first and tighten to the specified torque diagonally, unless a particular sequence is specified.

5. Clean parts in cleaning solvent upon disassembly. Lubricate any sliding surfaces before reassembly.

6. After reassembly, check all parts for proper installation and operation.

7. Many screws used in this machine are self-tapping. Be aware that cross-threading or over tightening these screws will strip the threads and ruin the hole.

8. Use only metric tools when servicing this engine. Metric bolts, nuts and screws are not interchangeable with nonmetric fasteners. The use of incorrect tools and fasteners will damage the engine.

9. Follow the instructions represented by these symbols when they are used.

Electric precautions

1. Hold the connector body to disconnect the connector. Do not disconnect by pulling the wire harness. To disconnect the locking connector, be sure to unlock first, and then disconnect.

2. Check the connector terminals for bend, excessive extrusion, missing terminal, or other abnormalities before connecting the connector.

3. To connect, insert the connector as full as it goes. If the connector is a locking type, be sure that it is locked securely.

4. Check the connector cover for breakage and check whether the connector female terminal is not open excessively. Then, connect the connector securely. Check the connector terminal for rust. Remove the rust using an emery paper or equivalent material before connecting the connector.

5. Set the harness clips in the specified places of the frame securely, and securely the wire harnesses.

6. Clamp the cables securely.

7. Clamp the wire harnesses securely so that they do not interfere with the rotating parts, moving parts and the hot parts.

8. Route and connect the wire harnesses properly. Be sure that the harnesses are not slack, twisted or pulled taut.

9. Route the wire harnesses properly so that they do not contact with the shape edges and corners, and the end of the bolts and screws on the body.
10. If a wire harness contacts the end of the bolts/screws or sharp edges and corners, protect the contact part of the harness with a tube or by winding with an electrician's insulating tape. If the wire harness has a grommet, set the grommet securely.
11. Take care not to pinch the wire harnesses during installation of a part. If a wire harness has the damaged insulation, repair by winding with the electrician's insulating tape.
12. Read the tester manufacture's operation instructions carefully before operation with tester. Follow the instructions of the Service Manual. Be sure that the battery built in a tester is fully charged and check the meter before inspection using the tester.

2.4 Serial number location

The engine serial number is stamped at the underside of engine side cover. Refer to these numbers when ordering or making technical inquiries.

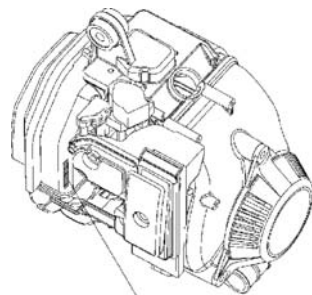

Engine serial number

11. Oil case/Crankshaft/Cylinder Block/Piston/Valve

11.1 Oil case/Crankshaft

a. Disassembly/Reassembly

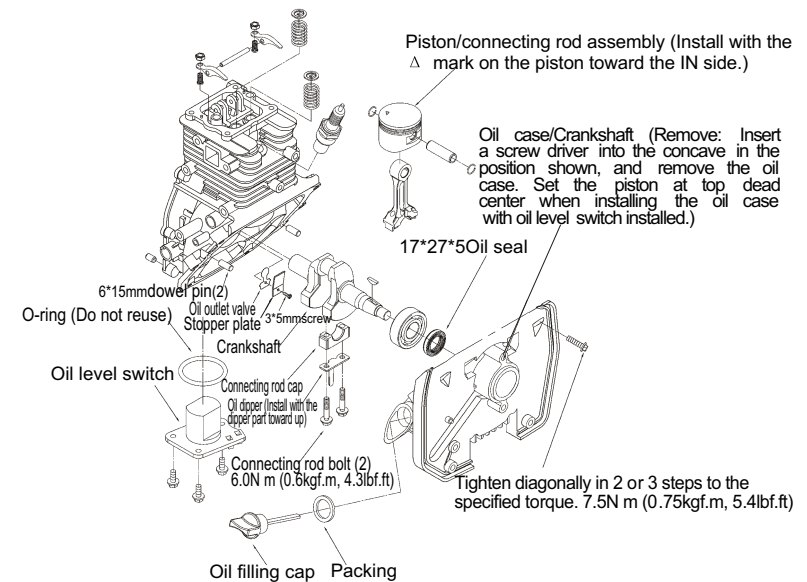

■Cam height

Standard	Service limit
27.972mm (1.1013in)	26.972mm (1.0619in)

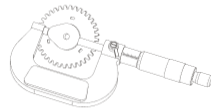

■Camshaft roller/Valve lifter roller O.D.

Standard	Service limit
4.990-5.000mm (0.1965-0.1969in)	4.950mm (0.1949in)

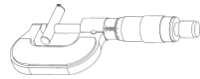

■Valve lifter I.D.

Standard	Service limit
5.005-5.025mm (0.1970-0.1978in)	5.050mm (0.1988in)

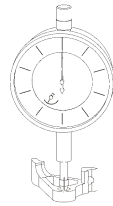

■Rocker arm shaft I.D.

Standard	Service limit
4.005-4.025mm (0.1577-0.1585in)	4.050mm (0.1594in)



■Rocker arm shaft O.D.

Standard	Service limit
3.990-4.000mm (0.1571-0.1575in)	3.950mm (0.1555in)

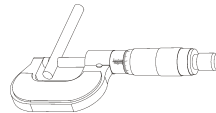

■Rocker arm shaft bearing I.D.

Standard	Service limit
4.000-4.108mm (0.1577-0.1582in)	4.050mm (0.1594in)

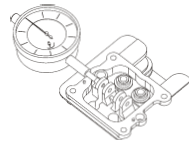

2.5 Maintenance standards

Part	Item	Standard(mm)	Service limit	
Engine	Maximum speed without load	5500 ± 100	—	
		0.42/1000	—	
Cylinder	Sleeve I.D.	43.5-43.52	43.58	
	Skirt O.D.	43.46-43.48	43.40	
Piston	Piston-to-cylinder clearance	0.03-0.05	0.120	
	Pin bore I.D.	10.002-10.0008	10.050	
Piston pin	O.D.	9.994-10.000	9.95	
	Pin-to-piston clearance	0.002-0.014	0.100	
Piston ring	Ring width Top	0.77-0.79	0.720	
	Ring width Second	0.97-0.99	0.920	
	Ring side clearance Top/second	0.02-0.06	0.120	
	Ring end clearance Top/second	0.02-0.06	0.600	
Connecting rod	Small end I.D.	10.006-10.017	10.050	
	Big end I.D.	15.000-15.011	15.040	
	Big end oil clearance	0.016-0.038	0.100	
	Big end side clearance	0.1-0.6	0.8	
Crankshaft	Crank pin O.D.	14.973-14.984	14.940	
Valves	Valve clearance	IN	0.08 ± 0.02	—
		EX	0.11 ± 0.02	—
	Stem O.D.	IN	3.970-3.985	3.900
		EX	3.935-3.950	3.800
	Guide	IN/EX	4.000-4.018	4.060
	Seat width	IN/EX	0.6-0.8	10
Valve spring	Free length	IN/EX	23.7	22.8
Cam wheel	Cam height	IN/EX	27.972	26.972
	I.D (shaft bore)		5.020-5.050	5.100
Camshaft	O.D.		4.990-5.000	4.950

Valve lifter	I.D (shaft bore)	5.005-5.025	5.050
Valve lifter shaft	O.D	4.990-5.000	4.950
Crankcase back cover	Camshaft Bearing I.D.	5.000-5.018	5.050
	Valve lifter shaft Bearing I.D	5.000-5.018	5.050
Cylinder block	Camshaft bore	5.000-5.018	5.050
	Valve lifter shaft bore	5.000-5.018	5.050
	Rocker arm shaft bore	4.000-4.018	4.050
Rocker arm	I.D(Rocker arm shaft bore)	4.005-4.025	4.050
Rocker arm shaft	OD	3.990-4.000	3.950
Carburetor	Main jet	#58	—
	Float height	12	—
	Pilot screw opening	2turns out	—
Spark plug	Gap	0.6 ~ 0.7	—
Ignition coil	Resistance Primary side	0.7 ~ 1.1 Ω	—
	Second side	12 ~ 21k Ω	—
Pulse coil (Trigger)	Air gap	0.5 ± 0.1	—
	Resistance	80 ~ 130 Ω	—

Generator

Part	Item	Type	Standard	Service limit
Exciter coil	Resistance	Yellow/Green-Green	1.1-1.6 Ω	—
Sub winding coil	Resistance	White-White	1.2-1.8 Ω	—
DC coil	Resistance	Blue-Blue	0.7-1.3 Ω	—
Main winding coil	Resistance	Black-Black	8.2-10 Ω	—

10.3 Inspection

■Crankcase side cover

Measure the I.D. of the camshaft roller bearing.

Standard	Service limit
5.000-5.018mm (0.1969-0.1976in)	5.050mm (0.1988in)

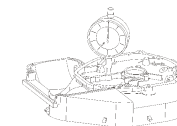

Measure the I.D. of the valve lifter bearing.

Standard	Service limit
5.000-5.018mm (0.1969-0.1976in)	5.050mm (0.1988in)

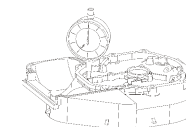

■Cylinder block

Measure the I.D. of the camshaft roller bearing.

Standard	Service limit
5.000-5.018mm (0.1969-0.1976in)	5.050mm (0.1988in)

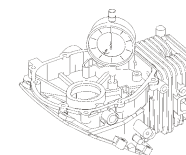

Measure the I.D. of the valve lifter bearing.

Standard	Service limit
5.000-5.018mm (0.1969-0.1976in)	5.050mm (0.1988in)

■Camshaft I.D.

Standard	Service limit
5.020-5.050mm (0.1976-0.1988in)	5.100mm (0.2008in)

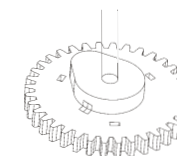

■ Crankcase side cover installation

- (1) Clean the mating surface of the side cover and the cylinder block with a degreasing cleaning or a clean shop towel.
- (2) Apply the stick 1.5-2.0 mm in the diameter of the liquid packing (Three Bond 1216 E or equivalent) to the mating surface of the cylinder block as shown.
- (3) Install the side cover on the cylinder block.

Be sure to assemble within 3 minutes after application of the liquid packing.

NOTE:

Assemble the side cover with the cylinder barrel within 3 minutes after application of the liquid packing.

- (4) Loosely tighten the bolts. then tighten them diagonally in 2 or 3 steps to the specified torque.

Torque:7.5N m (0.75kgf.m, 5.4lbf.ft)

- (5) Wait for 30 minutes after assembly. Do not add oil or start the engine during this period.

Camshaft installation(Valve timing adjustment)

Install the camshaft by aligning the alignment mark on the camshaft with the timing mark on the crankshaft.

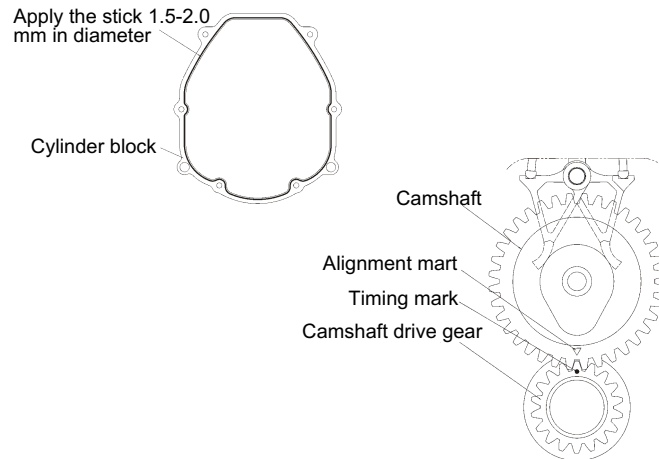

2.6 Torque values

Item	Thread dia. X pitch	Tightening torque		
		N.m	Kgf.m	Lbf.ft
Spark plug	M10 x 1.0	12	1.2	9
Crankcase side cover bolt	M5 x 0.8(CT)	7.5	0.75	5.4
Oil case bolt	M5 x 0.8(CT)	7.5	0.75	5.4
Connecting rod bolt	M5 x 0.8	6.0	0.60	4.3
Valve cover bolt	M5 x 0.8(CT)	6.0	0.60	4.3
Oil drain bolt	M8 x 1.25	11	1.1	8
Valve adjuster lock nut	M5 x 0.8	5.5	0.55	4.0
Rotor nut	M10 x 1.25	28	2.8	20
Fan cover bolt	M5 x 0.8(CT)	6.0	0.60	4.3
Maintenance cover screw	M6 x 1.0	2.3	0.23	1.7
Fuel pump tapping screw	5mm	0.8	0.08	0.6
Fuel valve tapping screw	5mm	1.4	0.14	1.0
Engine switch plate tapping screw	5mm	0.8	0.08	0.6
Cable clamp tapping screw	5mm	0.8	0.08	0.6
Ignition coil tapping screw	6mm	1.8	0.18	1.3
Muffler protector screw	M5 x 0.8	2.3	0.23	1.7
Control panel screw	M5 x 0.8	2.3	0.23	1.7
Front cover screw	M5 x 0.8	2.3	0.23	1.7
Ground screw	M5 x 0.8	2.3	0.23	1.7
Shroud screw	M4 x 0.8	0.9	0.09	0.7
Engine switch tapping screw	3mm	0.18	0.018	0.13
Carburetor drain screw	M6 x 1.0	1.5	0.15	1.1

Note:

Use standard torque values for fasteners that are not listed in this table.

(CT) indicates a self-tapping bolt.

Standard torque

Item	Thread dia. X pitch	Tightening torque		
		N.m	Kgf.m	Lbf.ft
Screw	3mm	1.0	0.1	0.7
	4mm	2.0	0.2	1.4
	5mm	4.2	0.42	3.0
	6mm	8.0	8.0	5.8
Flange bolt and nut	4mm	3.5	0.35	2.5
	5mm	5.5	0.55	4.0
	6mm	10	1.0	7
CT flange bolt	5mm	5.5	0.55	4.0
	6mm	10	1.0	7
SH(Small head)flange bolt	6mm	9	0.9	6.5

10.2 Crankcase side cover/Camshaft/Valve lifter

a. Disassembly/Reassembly

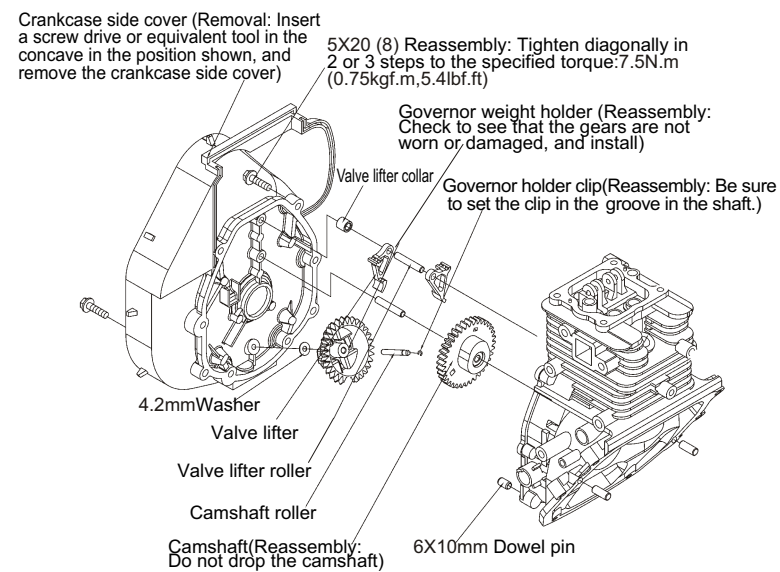

10. Camshaft/Rocker arm

10.1 Camshaft/Rocker arm

a. Disassembly/Reassembly

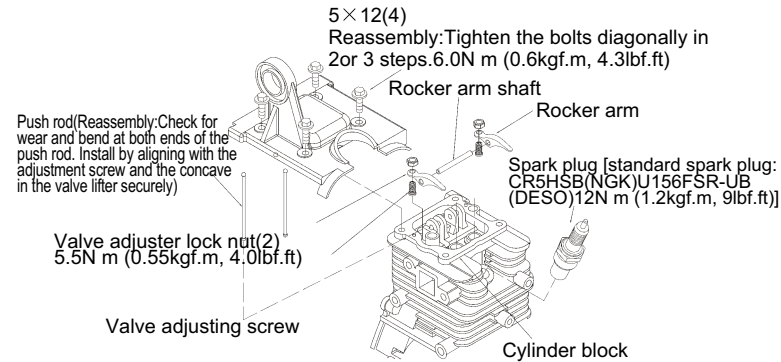

■ Valve covers installation:

(1) Clean the mating surfaces of the valve cover and the cylinder block with a degreasing cleaning agent or a clean shop towel.

(2) Apply the liquid packing (Three Bond 1207B or equivalent) to the position shown on the cylinder block.

Note:

Assemble the valve cover within 3 minutes after application of the liquid packing.

(3) Wait for 20 minutes after assembly. Do not add oil or start the engine during this period.

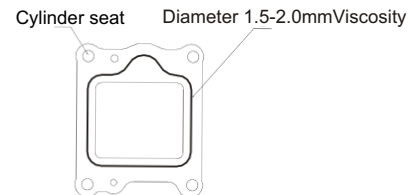

2.7 Troubleshooting

A. General symptoms and possible causes

Engine does not start or hard starting	Carburetor float chamber contains stale gasoline, or no fuel reaches to carburetor	Drain old fuel and check and clean
	Fuel tank tube clogged	Inspect
	Diaphragm tube disconnected	Connect
	Fuel filter clogged	Clean
	Fuel pump clogged	Inspect and replace
	Carburetor faulty	Readjust and/or disassemble and clean
	Spark plug cap disconnected	Install securely
	Pulse coil (Trigger) air gap incorrect	Readjust
	Ignition coil faulty	Inspect and replace
	Spark plug faulty	Inspect and replace
	Engine switch faulty	Inspect and replace
	Oil level switch (Low oil alarm) faulty	Inspect and replace
	Portfire faulty	Inspect and replace
	Pulse coil (Trigger) faulty	Inspect and replace
Exciter coil faulty	Inspect	
Valve clearance misadjusted	Adjust	
Throttle valve set in fully closed position when reassembling	Set in fully open position	
Engine speed does not stabilize, too high or too low	Carburetor faulty	Adjust and/or disassemble and clean
	Throttle control motor (stepping motor) faulty	Inspect
	Generator faulty	Troubleshoot
	Inverter unit faulty	Troubleshoot
	Valve clearance misadjusted	Adjust

B. Engine

Hard starting

If the engine does not start or hard starting after reassembly, check to see whether the throttle valve is at the full open position.

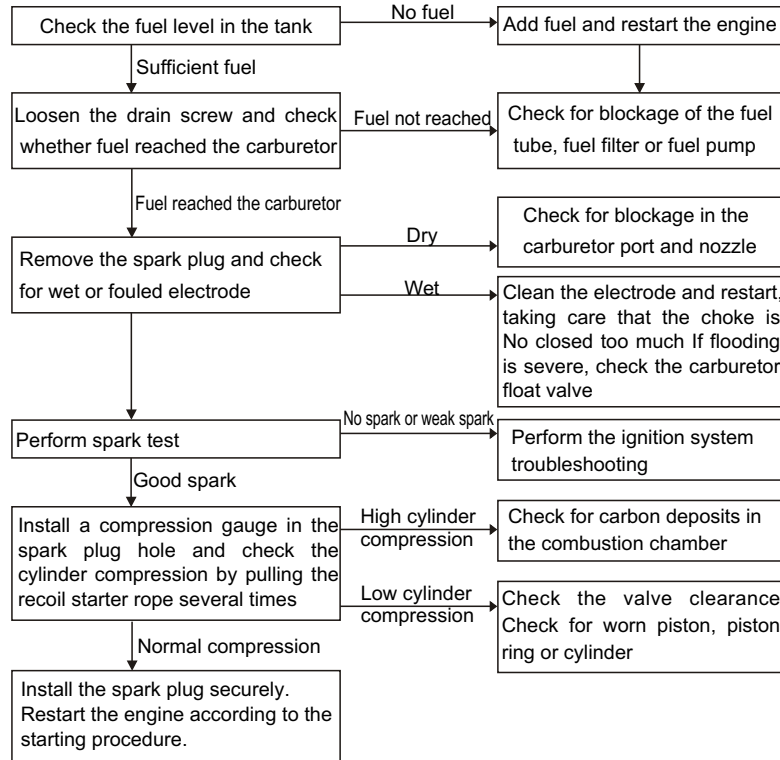

Cylinder compression check

1. Remove the spark plug cap and spark plug, and install a compression gauge in the spark plug hole.
2. Pull the recoil starter rope several times with force and measure the cylinder compression.

Cylinder compression	0.42Mpa(4.3kgf/cm ²)/1000rpm
----------------------	--

AC coil:

Measure the resistance between the red, white, and blue terminals of the 6P connector.

Resistance	Black-Black 8.2-10 Ω
------------	----------------------

If the resistance is out of the specification, inspect the generator wire harness. Replace the generator wire harness if necessary.

If the generator wire harness is normal, replace the stator assembly.

DC coil:

Measure the resistance the blue terminals of the rectifier.

Resistance	0.7-1.3 Ω
------------	-----------

If the resistance is out of the specification, inspect the generator wire harness. Replace the generator wire harness if necessary.

If the generator wire harness is normal, replace the stator assembly.

c. Adjustment

Pulse coil-to-rotor clearance

Insert a feeler gauge between the pulse coil and the projection of the rotor.

With the pulse coil pushed against the rotor, tighten the 5X12 mm flange bolt.

Air gap	0.5 ± 0.1mm(0.020 ± 0.004in)
---------	------------------------------

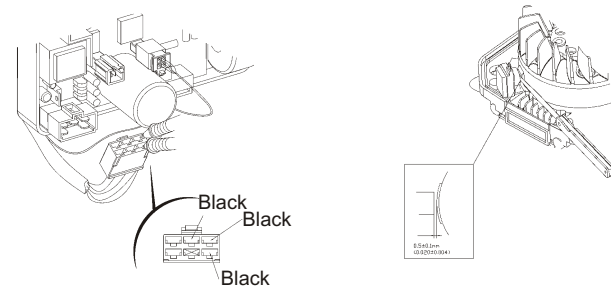

- (4) Install cooling fan and the fan cooling boss; tighten the 6x16mm flange bolt.
- (5) Align the locking tab of the recoil starter pulley with the groove in the cooling fan boss, and install the pulley.
- (6) Holding the rotor with a strap wrench, and tighten the 6x16mm flange bolt.
- (7) Install the pulser coil and adjust the clearance between the pulser coil and rotor.

b. Inspection

Pulser coil

Measure the resistance between the terminals A and B.

Resistance	25-39 Ω
------------	---------

■ Stator

Exciter coil:

Measure the resistance between the green terminal and yellow/green terminal

Resistance	1.1-1.6 Ω
------------	-----------

If the resistance is out of the specification, inspect the generator wire harness.

Replace the generator wire harness if necessary.

If the generator wire harness is normal, replace the stator assembly.

Sub coil:

Measure the resistance between the white and white terminals of the 6P connector.

Resistance	1.2-1.8 Ω
------------	-----------

If the resistance is out of the specification, inspect the generator wire harness.

Replace the generator wire harness if necessary.

If the generator wire harness is normal, replace the stator assembly.

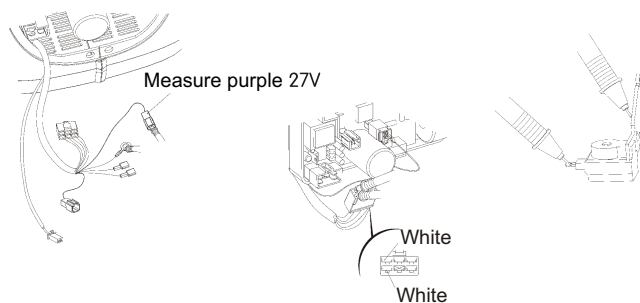

Compression gauge (commercially available)

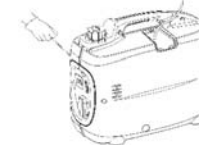

Engine starts but then stalls

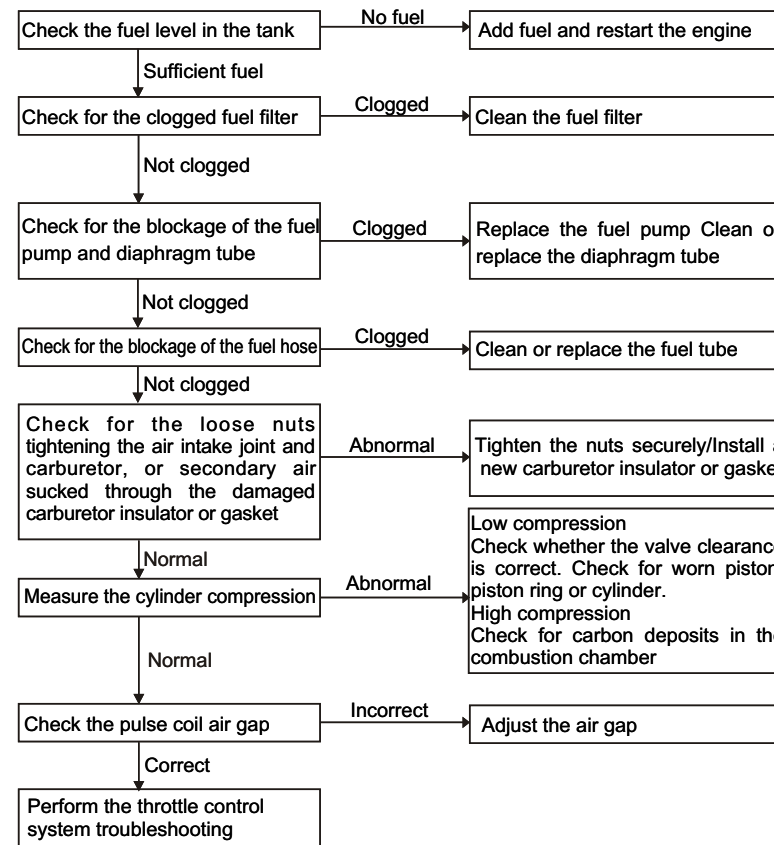

Engine speed does not increase or stabilize

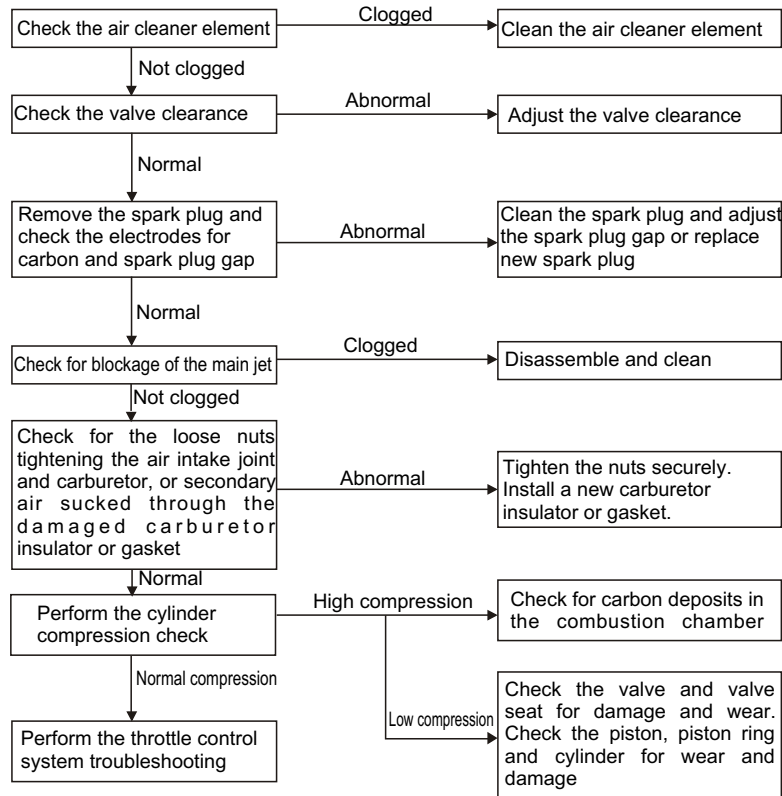

■ ROTOR REMOVAL

(1) Remove the pulser coil.

(2) Holding the rotor with a strap wrench, and remove the 6x16mm flange bolt.

CAUTION:

Don't remove the bolt by a screwdriver or equivalent tool on the fan blade.

(3) Remove recoil starter pulley.

(4) Remove 6x16mm flange bolt, and remove cooling fan boss and cooling fan.

(5) Holding the rotor with a strap wrench, then remove 10mm flange nut.

CAUTION:

Don't remove the nut by striking it with a hammer or equivalent tool.

(6) Remove the rotor using the fly wheel puller.

■ Rotor installation:

CAUTION:

Remove the dust and oil from the tapered part of the crankshaft and rotor.

Check to see whether the magnetic part of the rotor is free from metallic part, washer, etc.

(1) Set the woodruff key in the key groove securely.

(2) Install the rotor on the crankshaft.

(3) Holding the rotor with a strap wrench, tighten the 10mm flange nut to the specified torque.

TORQUE: 28N m (2.8kgf.m, 20lb.ft)

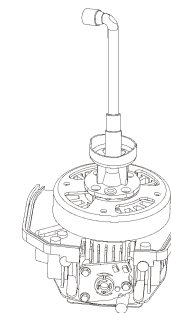
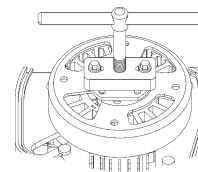
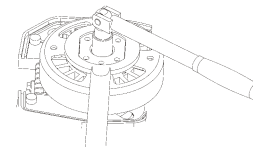

9. Generator

9.1 Generator

a. Disassembly/Reassembly

- (1). Remove the muffler protector.
- (2). Remove the control panel
- (3). Remove the right and left side covers.
- (4). Remove the fuel tank.
- (5). Remove the inverter unit and engine bed.
- (6). Remove the recoil starter and fan cover.

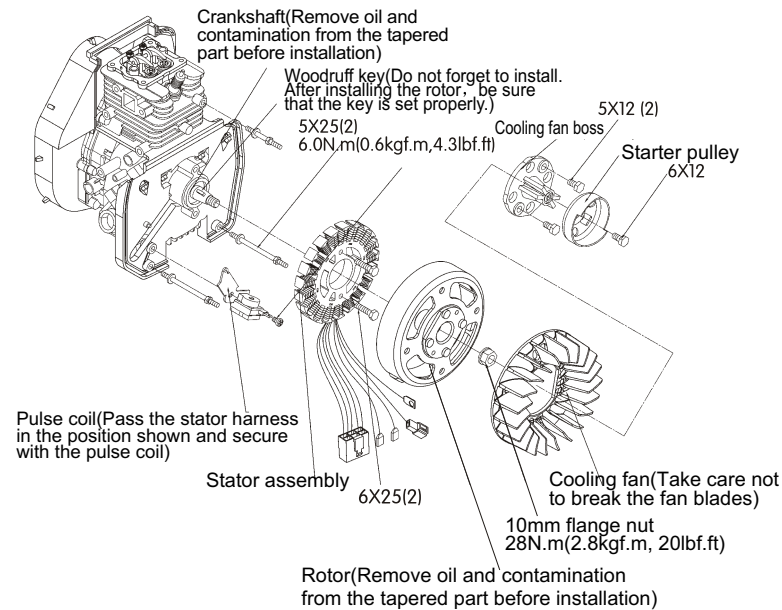

C. Ignition system

Spark test



■ Do not pull the recoil starter rope while touching the high tension wire. High voltage generates, which is very dangerous. Be sure to ground the spark plug and hold the plug cap to perform the spark test.

■ Gasoline is extremely flammable and explosive. If ignited, gasoline can burn you severely. Be sure there is no spilled fuel near the engine

- 1) Drain the gasoline from the fuel tank and carburetor.
- 2) Remove the spark plug cap and spark plug.
- 3) Pull the recoil starter several times to release the unburnt gas in the cylinder with the engine switch OFF.



■ Unburnt gas can ignite if it is left in the cylinder. Be sure to drain the fuel tank and carburetor thoroughly before spark test, and release the unburnt gas from the cylinder by pulling the recoil starter several times.

- 4) Attach the removed spark plug to the plug cap.
- 5) Set the ignition switch to the ON position. Ground the negative (-) electrode (i.e. threaded part) of the spark plug against the shroud and pull the recoil starter rope to check whether sparks jump across the electrodes.

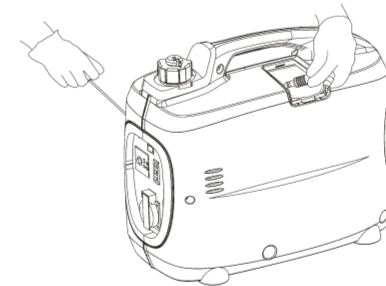

Engine does not start with sufficient oil in the crankcase

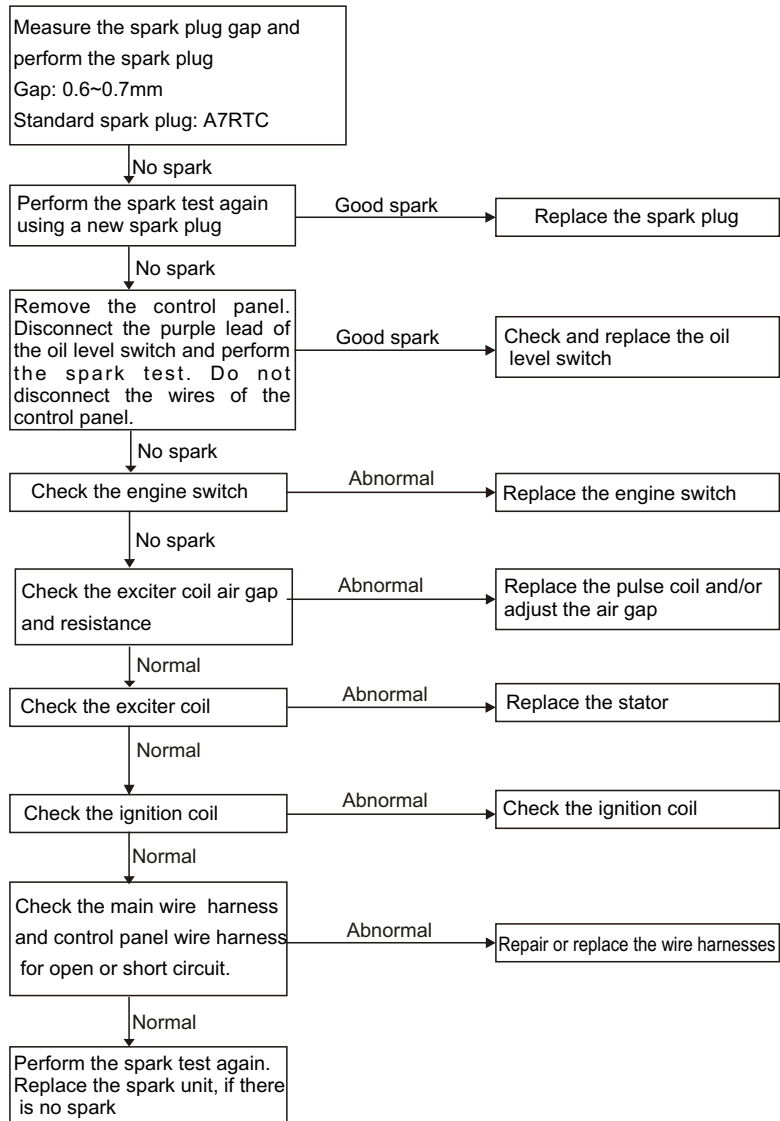

8.3 Exhaust manifold/Carburetor insulator

a. Disassembly/Reassembly

(1) Remove the fan shroud

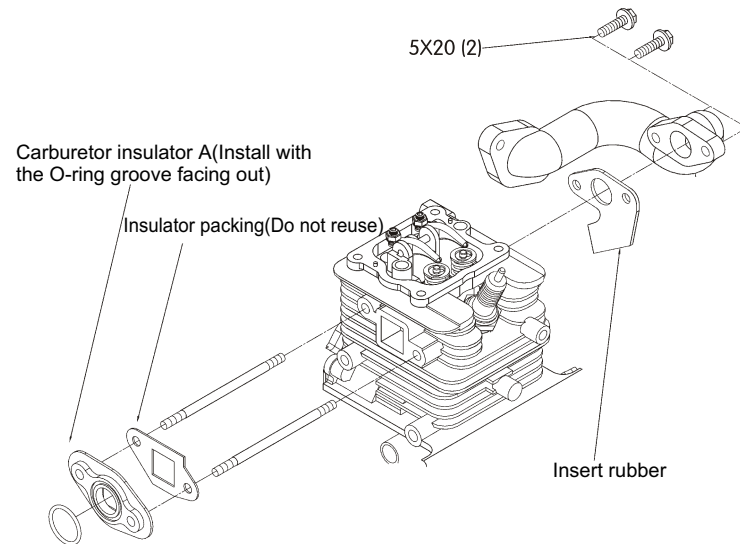

8.2 Fan shroud

A. Disassembly/Reassembly

- (1) Remove the muffler protector
- (2) Remove the control panel
- (3) Remove the right and left side covers
- (4) Remove the fuel tank
- (5) Remove the inverter and engine end
- (6) Remove the recoil starter and fan cover

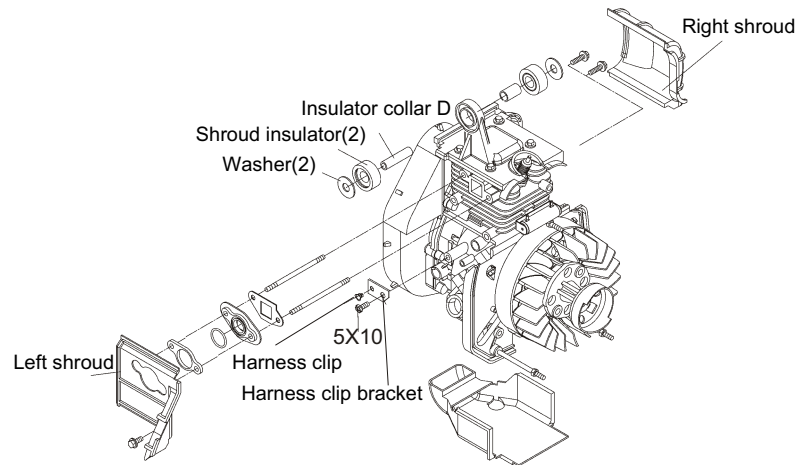

Engine oil level is low, but engine does not stop

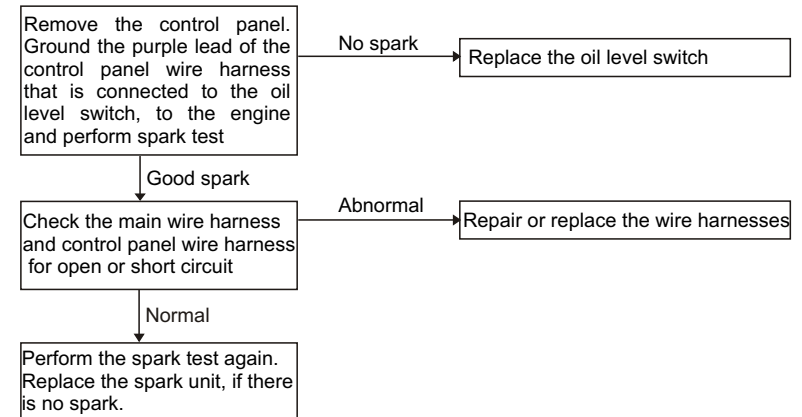

D. Throttle control system

Engine speed is too high, hunting

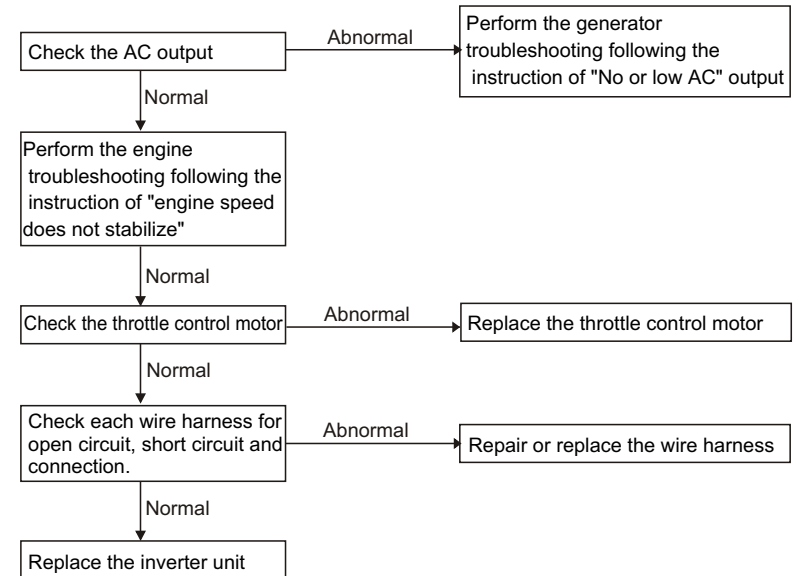

Engine speed too low

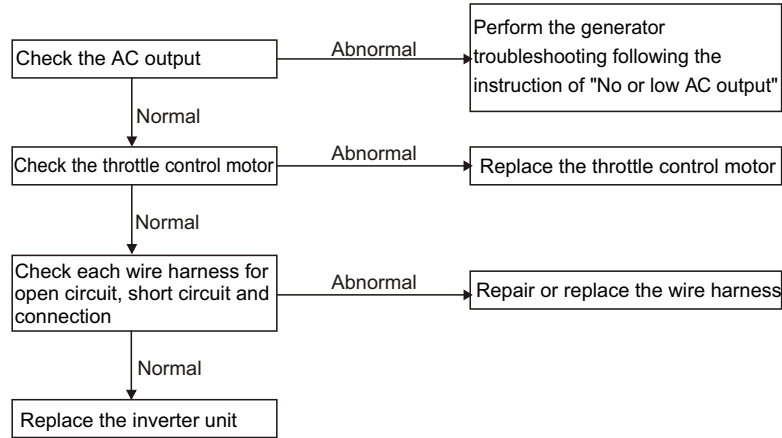

Engine speed does not increase with ECO Throttle System OFF under no load.
 Engine speed does not decrease with ECO Throttle System ON under no load.
 Engine speed does not increase by connecting load with ECO Throttle System ON.

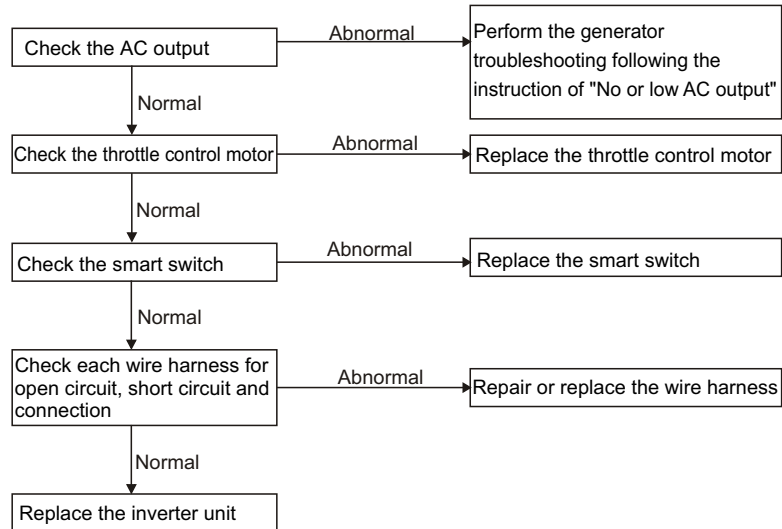

b. Inspection

Ignition coil

(Primary resistance)

Attach one lead of the tester to the lead wire terminal and another tester lead to the ground wire terminal, and measure the primary resistance of the ignition coil.

Resistance	0.7-1.1Ω
------------	----------

(Second resistance)

Attach one lead of the tester to the terminal inside the spark plug cap and another lead to the ground wire terminal, and measure the secondary resistance of the ignition coil.

Resistance	12-21KΩ
------------	---------

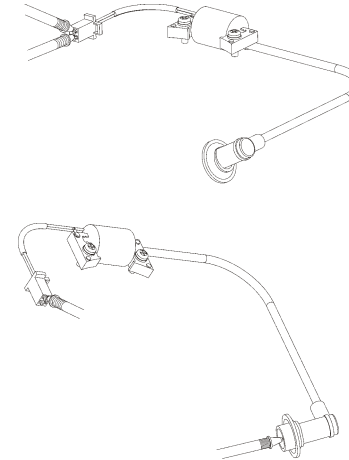

- (2) Pass the starter rope through the rope hole in the reel and make a knot at the rope end. Wind the rope around the recoil starter reel in the direction of the arrow.
 - (3) Align the hook at the inner end of the recoil starter spring with the groove in the case so that the hook sets in the groove, and install the reel in the case.
 - (4) Pass the starter rope through the cutout in the starter reel, and turn the starter reel approximately 3 turns in the direction of the arrows to preload the spring.
 - (5) Make sure that the rope grommet is in the place. Pull out the rope end from the hole in the case. Pass the rope end through the starter rope guide and starter grip and make a knot at the rope end.
 - (6) Install the grip cover.
 - (7) Install the swing arm collar. Install the swing arm set and friction as shown, and secure the starter reel with the set screw.
- Pull the starter knob several times and be sure that the swing arm operates normally.

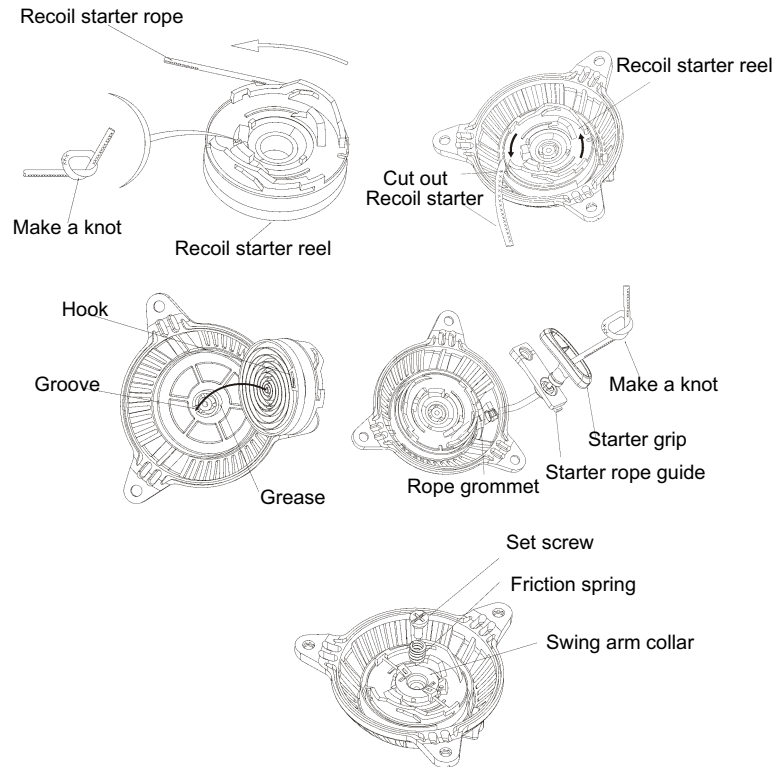

E. Generator
No or low AC output
Engine running

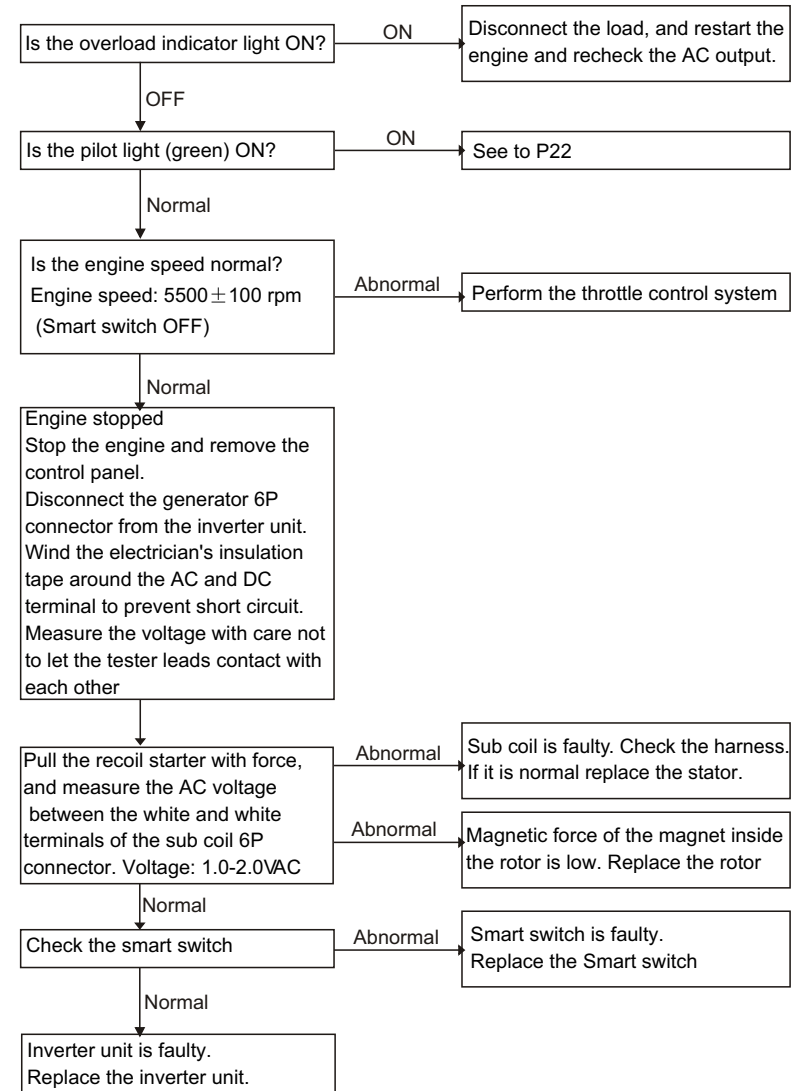

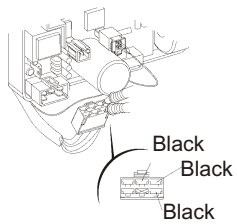
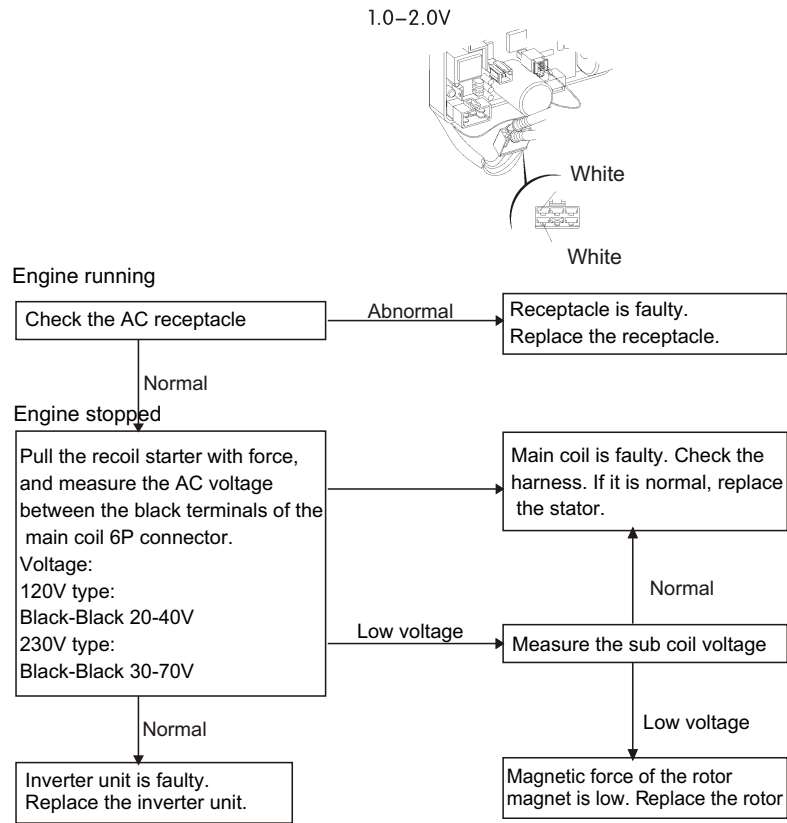

■ Recoil starter disassembly

Caution:

Wear heavy gloves during operation.

Take care not to allow the recoil starter spring to pop out.

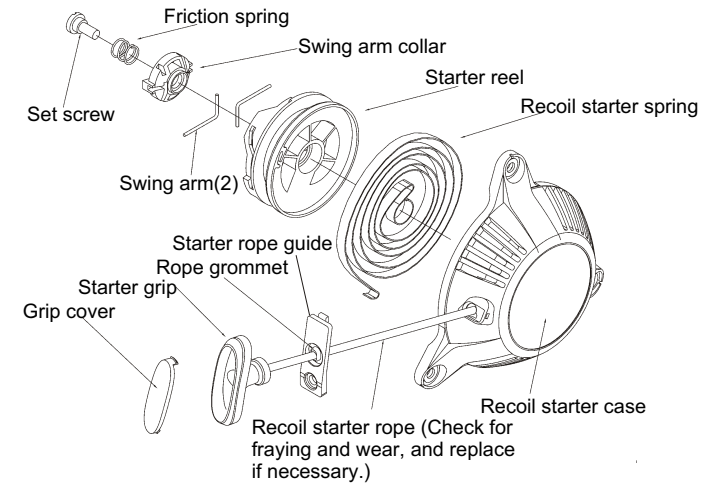

■ Recoil starter reassembly

Caution:

Wear heavy gloves during operation.

Take care not to allow the recoil starter spring to pop out.

(1) Set the hook at the outer end of the recoil starter spring in the groove in the starter reel.

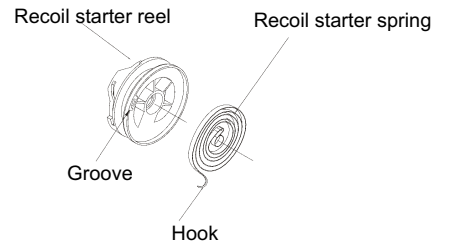

8. Recoil starter/Fan cover

8.1 Recoil starter/Fan cover

a. Disassembly/Reassembly

- (1) Remove the muffler protector
- (2) Remove the control panel
- (3) Remove the right and left side covers
- (4) Remove the fuel tank
- (5) Remove the inverter and engine end

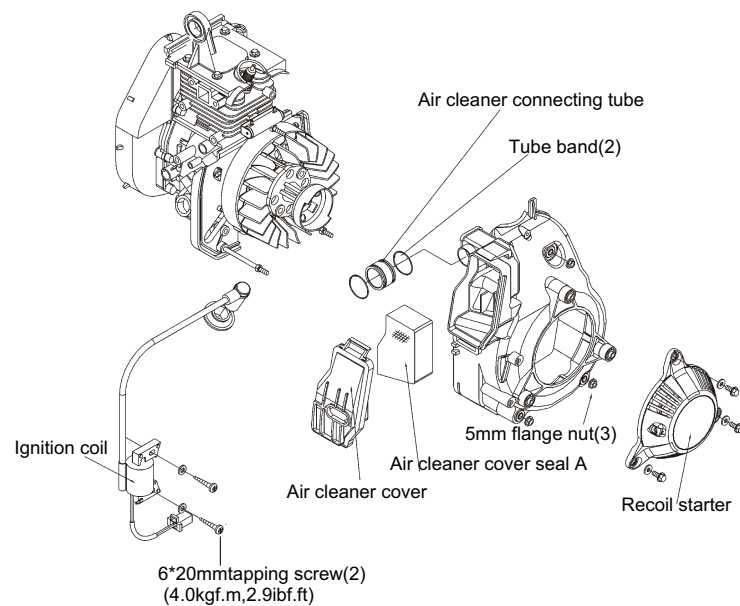

No DC output
Engine running

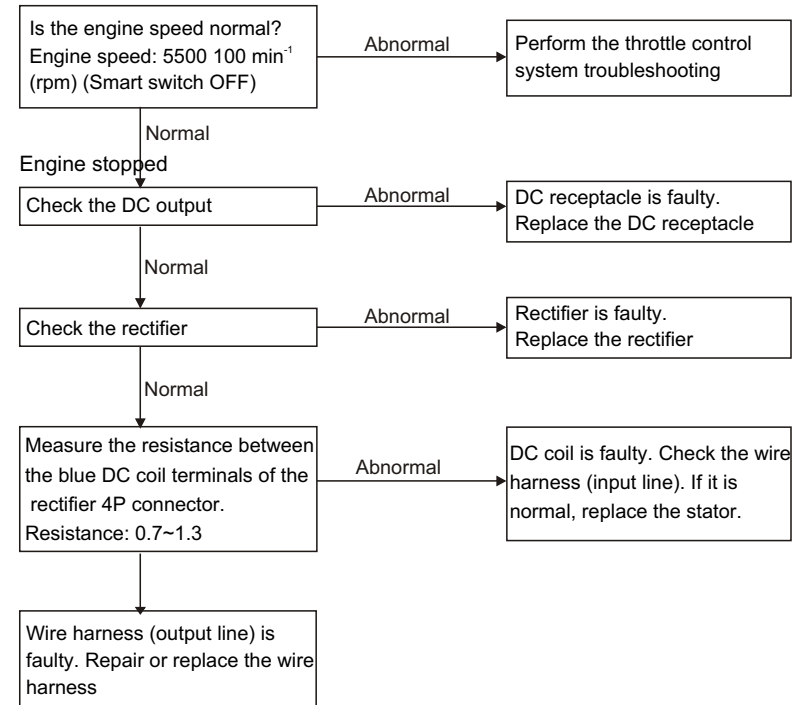

2.8 Cable / Harness routing
Wire harness

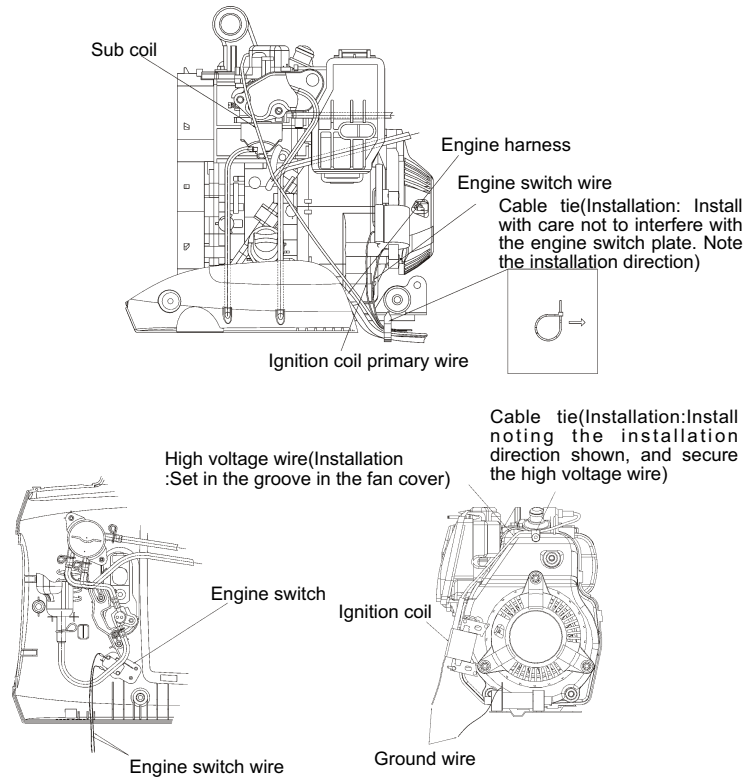

7.3 Inverter unit/Engine bed

a. Disassembly/Reassembly

- 1) Remove the muffler protector
- 2) Remove the control panel
- 3) Remove the right and left side covers
- 4) Remove the fuel tank

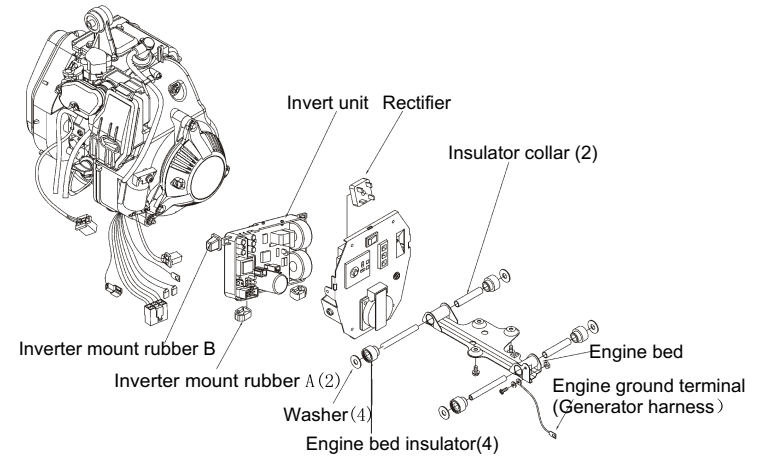

b. Inspection

Rectifier

Check for continuity between the terminals according to the table below.

Tester lead(+)	1	2	3	4
Tester lead(-)				
1		---	---	---
2	Continuity		Continuity	Continuity
3	Continuity	---		---
4	Continuity	---	---	

7.2 Fuel tank

a. Disassembly/Reassembly



Gasoline is highly flammable and explosive. You can be burned or seriously injured when handling fuel. Keep heat, sparks, and flame away. Wipe up spills immediately. Loosen the drain screw to drain the carburetor thoroughly before removal.

- 1) Remove the muffler protector
- 2) Remove the control panel
- 3) Remove the right and left cover

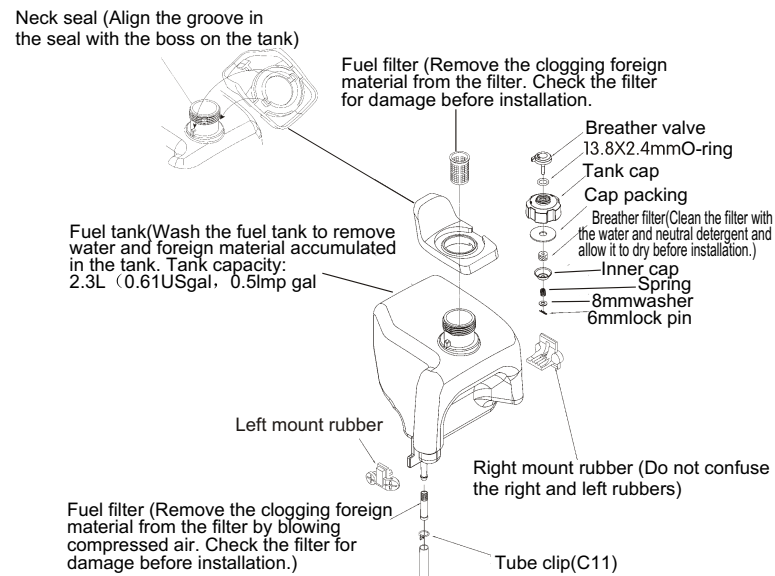

■ Tubes

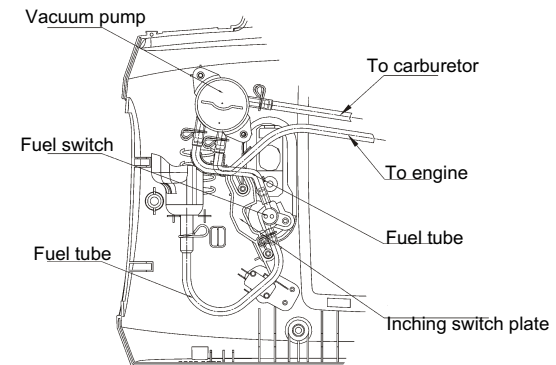
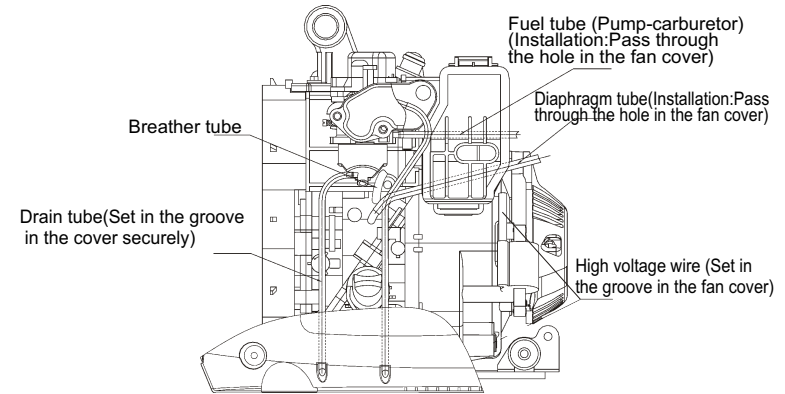

3. Maintenance

3.1 Maintenance schedule

Regular service period(1)		Each use	First month or 10 Hrs	Every 3 months or 50Hrs	Every 6 months or 100 Hrs	Every year or 300 Hrs
Item perform at every indicated month or operating hour interval, whichever comes first	Check	○				
	Replace		○		○	
Air cleaner	Check	○				
	Clean			○(2)		
Spark plug	Clean-Adjust				○	
Valve clearance	Check-Adjust					○
Fuel tank and filter	Clean					○
Fuel line	Check	Every 2 years (Replace if necessary)				

Note:

(1) For commercial use, operation hours are determined by proper maintenance.

(2) Service more frequently when operating in dusty areas.

3.2 Checking for the low oil alarm

This section mainly covers the measures taking while the engine oil changes.

1. Drain the oil and do the spark test. The low oil alarm should be ON and there are no sparks between the spark plug electrodes.
2. Feed the oil to the specified level/position and do spark test. The low oil alarm should be OFF and there are sparks jumping at the spark plug electrodes.
3. If there is still abnormality, please perform the ignition system troubleshooting.

2) Install the inverter and the fuel tank on the engine assembly.

3) Connect the engine switch wire 2P connector to the generator harness, and secure with the cable tie.

4) Connect the diaphragm tube and the fuel tube (pump-to-carburetor) to the fuel pump.

5) Set the engine unit on the left side cover, and check the following:

Tank mount rubber is set in the groove and over the boss of the cover.

Cover is set in the groove in the fuel tank neck seal.

Inverter mount rubber B aligns with the set part of the cover.

6) Lower the left side cover.

7) Set the engine bed insulator in the designated position of the left side cover.

Take care not allow the washer to come off.

8) Install the insulator collar A and insulator collar B securely.

9) Install the insulator collar C and insulator collar D securely.

10) Install the right tank mount rubber.

11) Check to see whether the cover seal A and cover seal B are securely set in the groove in the right side cover.

12) Install the right side cover on the left side cover, and check the following.

Covers are set in the groove in the fuel tank neck seal.

Left side cover is securely set in the groove in the right side cover.

Tank mount rubber is securely set in the groove and over the boss of the cover.

13) Tighten the 6mm washers, 6X100mm screws and 6X20mm screw washers securely.

14) Stand the generator upright. Turn up the neck seal and install the 10mm circlip.

b. Inspection

■ Engine switch

Check for continuity between the switch terminals. There must be no continuity with the switch turned ON, and there must be continuity with the switch turned OFF.

Note:

Check with the left side cover installed. Do not remove the left side cover unless it is replaced.

C. Installation

(1) Check the harness and tubes of the left side cover

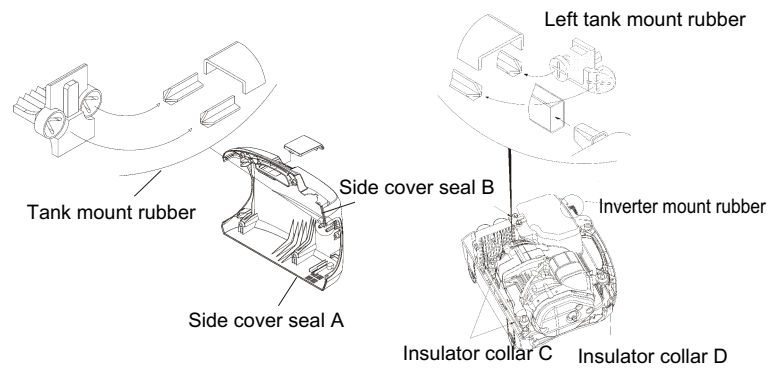
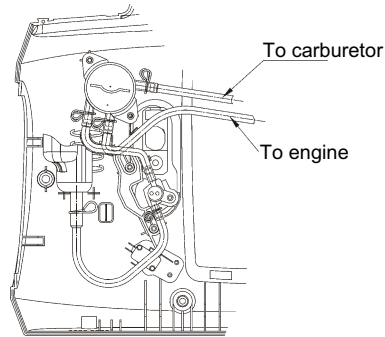

3.3 Engine oil

Checking for the oil level

Stop the engine and check the oil level, be sure to put the engine on a flat floor when checking.

(1) Loosen the screws of the maintenance cover and remove the cover.

(2) Remove the oil filler cap and check for the oil level. It should be at the lower edge of the oil filler port.

(3) If the oil level is low, add to the edge of the oil filler port.

Check the oil if it is stale or contaminated with the foreign material.

Recommended oil: SAE10W-30 or SAE30, API Service Classification SE, SF or SG.

Oil is a major factor affecting performance and service life. Use 4-stroke automotive detergent oil.

SAE10W-30 is recommended for general use. Other viscosities shown in the chart may be used when the average temperature in your area is within the recommended range.

(4) Install the oil filler cap.

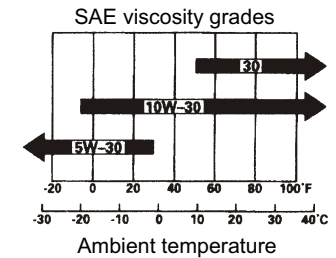
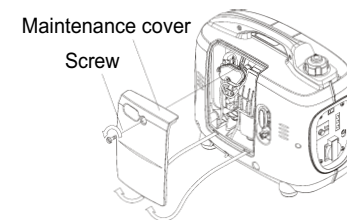
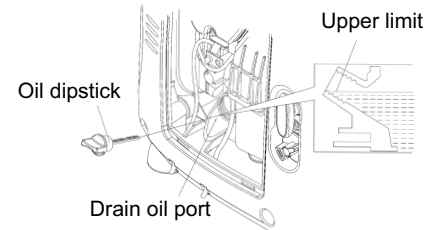

■ Oil change:

Drain the used oil while the engine is warm. Warm oil drains quickly and completely.

1). Remove the maintenance cover. Remove the oil filler cap and drain the engine oil into a suitable container.

Please dispose of the used motor oil in a manner that is compatible with the environment. We suggest you take used oil in a sealed container to your local recycling center or service station for reclamation. Do not throw it in the trash; pour it on the ground, or down a drain.

Caution

Used engine oil contains substances that have been identified as carcinogenic. If repeatedly left in contact with the skin for prolonged periods, it may cause skin cancer. Wash your hands thoroughly with soap and water as soon as possible after contact with used engine oil.

2). Pour the specified amount of fresh engine oil through the oil filler port.

Engine oil capacity: 0.25L (0.26US qt, 0.22Imp qt)

3). After refilling, check the oil level again. If the level is low, add to the lower edge of the filler neck.

4). Install the maintenance cover.

3.4 Air cleaner

A dirty air cleaner will restrict air flow to the carburetor, reducing engine performance. If the engine is operated in dusty areas, clean the air cleaner more often than specified in the Maintenance Schedule.

Inspection/Cleaning:

- 1) Loosen the cover screw and remove the maintenance cover.
 - 2) Disengage the locking tab by pushing it, and remove the air cleaner cover.
 - 3) Remove the element from the air cleaner case.
 - 4) Clean the element in warm soapy water, rinse and allow to dry thoroughly, or clean with a high flash point solvent and allow to dry.
- Dip the element in clean engine oil and squeeze out all the excess oil. Excess oil will restrict air flow through the foam element and may smoke at the engine start.

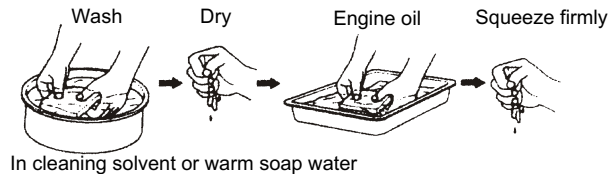

B. Disassembly/Reassembly

■ Left side cover

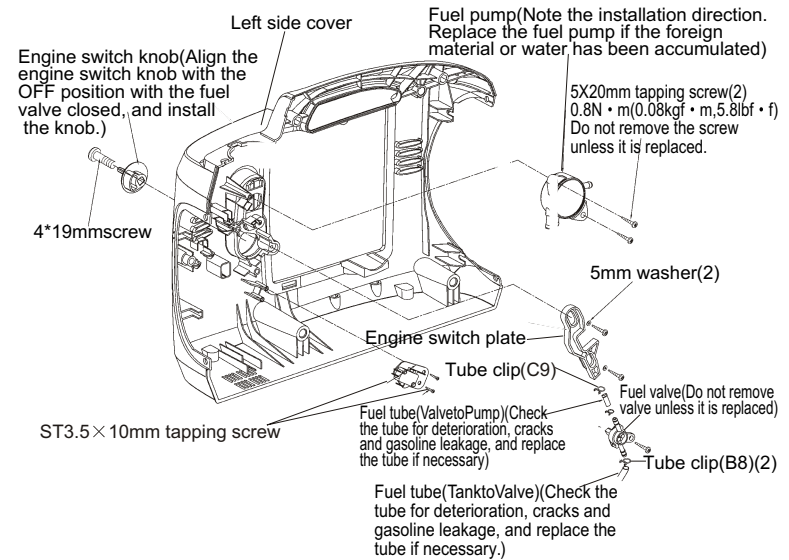

7. Side covers/ Fuel tank/ Inverter unit

7.1 Side covers

a. Removal



Warning

Gasoline is highly flammable and explosive. You can be burned or seriously injured when handling fuel. Keep heat, sparks, and flame away. Wipe up spills immediately. Loosen the drain screw to drain the carburetor thoroughly before removal.

Side cover removal/ installation can be made with the carburetor and muffler installed.

- 1) Remove the muffler protector
- 2) Remove the control panel
- 3) Remove the maintenance cover and drain the engine oil into a suitable container.

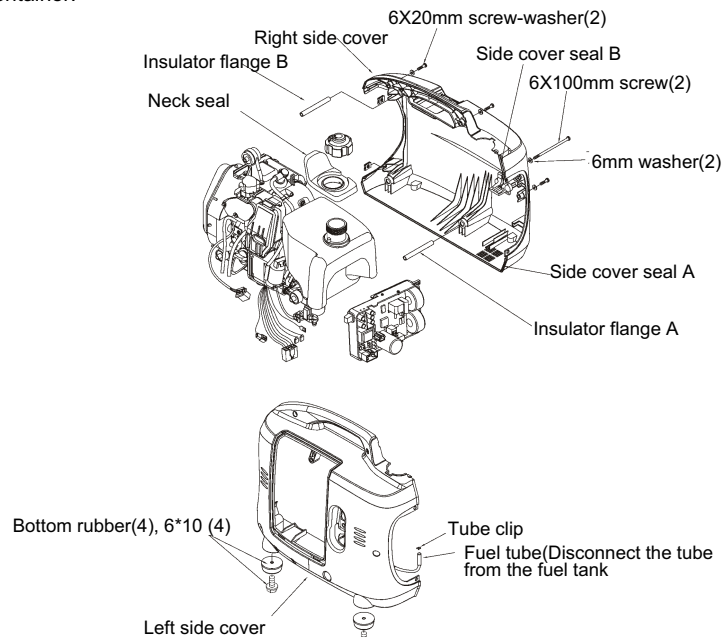

-44-

- 5) Install the air cleaner element in the air cleaner case.

Clean the air cleaner rubber and the air cleaner case if necessary. Be sure that the air cleaner cover seals are set securely.

- 6) Install the air cleaner cover.

Align the lower alignment part of the air cleaner cover, and lock the locking tab at the top of the air cleaner cover.

Be sure that the air cleaner cover seals are set securely. Replace the cover sealing ring A if damaged.

- 7) Install the maintenance cover securely.



Caution

Loosely installed air cleaner cover can come off by vibration during running. Operation the engine without an air cleaner element or with a damaged air cleaner element will allow dirt to enter the engine, causing rapid engine wear.

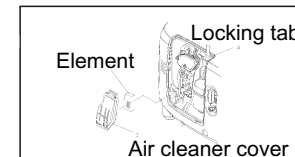

3.5 Spark plug

Inspection/Cleaning:

Allow the engine to cool before proceeding.

- 1) Remove the plug cover and remove the spark plug cap.
 - 2) Remove the spark plug.
- Visually inspect the spark plug. Discard the plug if the insulator is cracked or chipped.
- 3) Remove carbon or other deposits with a plug cleaner or stiff ire brush. Check the sealing washer for damage.
 - 4) Measure the plug gap with a wire-type feeler gauge. If the measure is outside 0.6-0.7mm (0.024-0.028in), adjust by bending the side electrode.
- Recommended spark plug: A7RTC
- 5). Install the plug finger tight to seat the washer, and then tighten with a plug wrench.

If reinstalling the used spark plug, tighten 1/8-1/4 turn after the spark plug seats.

If installing a new spark plug, tighten 1/2 turn after the spark plug seats.

Caution: A loose spark plug can become very hot and can damage the engine. Over tightening can damage the threads in the cylinder barrel.

- 6) Install the spark plug cap and plug cover.

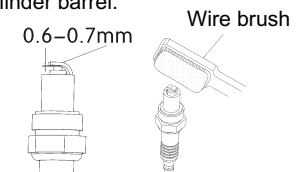

-29-

3.6 Valve clearance

Caution:

Valve clearance inspection and adjustment must be performed with the engine cold.

Inspection/Adjustment:

1) Remove the following parts:

- Muffler protector
- Front cover, control panel
- Right/left side covers
- Fuel tank
- Inverter unit, engine bed
- Recoil starter, fan cover
- Right/left shrouds

2) Remove the four 5X12mm flange bolts.

3) Loosen the cylinder head cover by slightly prying up each corner, and then remove the cylinder head cover.

Catch up the spilled engine oil with a suitable material when removing the cylinder head cover.

Caution:

Do not remove the cylinder head cover with excessive force. It can deform the cylinder head cover. Replace the cylinder head cover if it is deformed.

4) Turn the rotor to set the piston at top dead center of the compression stroke.

Right end of the projection on the rotor should align with the corner of the pulse coil bracket, and both the inlet and exhaust valve should be closed.

5) Insert a feeler gauge between the rocker arm and the valve and measure the valve clearance.

Valve clearance	IN	0.06-0.10mm (0.0024-0.0039in)
	EX	0.09-0.13mm (0.0035-0.0051in)

6) If adjustment is necessary, proceed as follows.

- a. Loosen the adjusting screw lock nut and adjust the valve clearance by turning the adjusting screw in or out. Increase the valve clearance by loosening the screw; decrease the valve clearance by tightening the screw.
- b. Holding the adjusting screw with a socket wrench, tighten the lock nut to the specified torque. The specified torque: 5.5N.m (0.55kgf.m, 4.0lbf.ft).
- c. After tightening the lock nut, check the valve clearance again.

Test method:

Test the resistance between the each circuit with a meter. The minus testing pen (general black) contact with the metal outer case of the engine, the positive testing pen (general red) respectively contact with each wire harness of 10P connector.

According to the table below, the normal resistance is:

Color	Circuit unit	Test and result
Blue	Primary coil of the ignition coil	0.7-1.1 Ω
Orange	Oil level switch	There should be no continuity with correct oil level
Yellow	Pulse coil	80-130 Ω
Yellow/Green	Ground	0 Ω
Green	Ignition unit power coil exciter coil	1.1-1.6 Ω
Red	Engine switch	There should be no continuity with the switch ON, continuity with the switch OFF

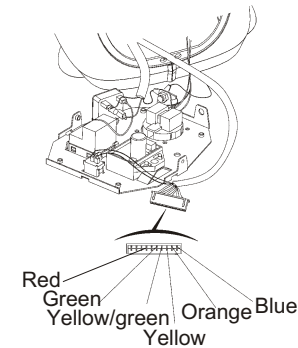

c. Inspection

■ AC receptacle

Connect both terminals of the receptacle with a jumper wire to short. There must be continuity between the lead wire terminals.

There must be continuity between the ground terminal of the receptacle and the receptacle installation fitting.

■ DC receptacle

Connect both terminals of the receptacle with a jumper wire to short. There must be continuity between the lead wire terminals with the circuit protector ON.

■ Composite socket

There must be continuity between the socket and the terminal.

■ ECO Switch

There must be continuity between the terminals with the switch ON, and no continuity with the switch turned OFF.

■ Spark unit

1) Remove the front cover.

2) Remove the two 5X20mm screws and pull off the control panel from the generator. Do not disconnect the control panel wire harness.

3) Disconnect the 10P spark unit connector from the spark unit.

4) Test the wire harness according to the table below. If it is normal, replace the spark unit.

7) Clean the cylinder head cover installation surface of the cylinder block and cylinder head cover. Apply the liquid gasket (Three Bond 1207B or equivalent) to the cylinder block installation surface as shown, and install the cylinder head cover.

8) Tighten the 5 X12mm flange bolts.

Torque: 6.0 N.m (0.6 kgf.m, 4.3 lbf.ft)

9) Install the removed parts in the reverse order of removal.

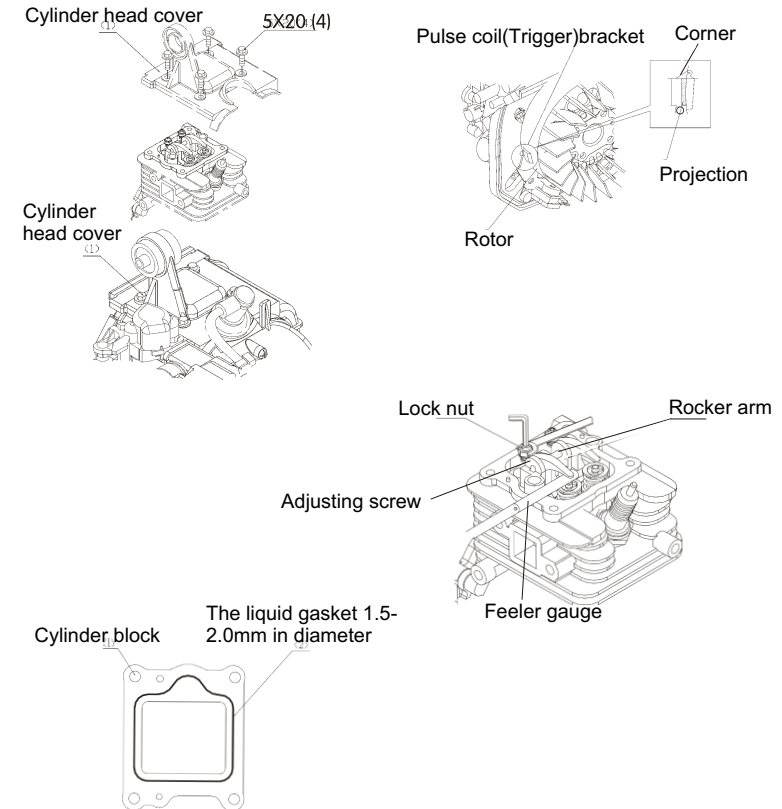

3.7 Fuel tank/Fuel filter



Gasoline is highly flammable and explosive. You can be burned or seriously injured when handling fuel. Keep heat, sparks, and flame away. Wipe up spills immediately.

Cleaning:

- 1) Drain the fuel from the tank and carburetor, then remove the following parts.
 - Muffler protector
 - Front cover and control panel
 - Right side cover
- 2) Disconnect the fuel tube from the fuel tank, and remove the fuel strainer.
- 3) Remove the clogged foreign material from the fuel filter, and check the fuel filter for damage. Replace the fuel filter if necessary.
- 4) Remove the fuel tank and clean it with cleaning solvent and allow the fuel tank to dry thoroughly.
- 5) After cleaning, install the fuel tank and set the fuel strainer in the tank. Connect the fuel tube.
- 6) Install the removed parts in the reverse order of removal.
- 7) Fill the fuel tank with gasoline and check the fuel tube for gasoline leakage.

3.8 Fuel tube/ Fuel pump



Gasoline is highly flammable and explosive. You can be burned or seriously injured when handling fuel. Keep heat, sparks, and flame away. Wipe up spills immediately.

Inspection/Replacement:

- 1) Drain the fuel from the tank and carburetor, then remove the following parts.
 - Muffler protector
 - Front cover and control panel
 - Right and left side cover
- 2) Check the fuel tube for deterioration, cracks and gasoline leakage.
If there is any abnormality in the fuel tube, replace the tube.

b. Disassembly/Reassembly

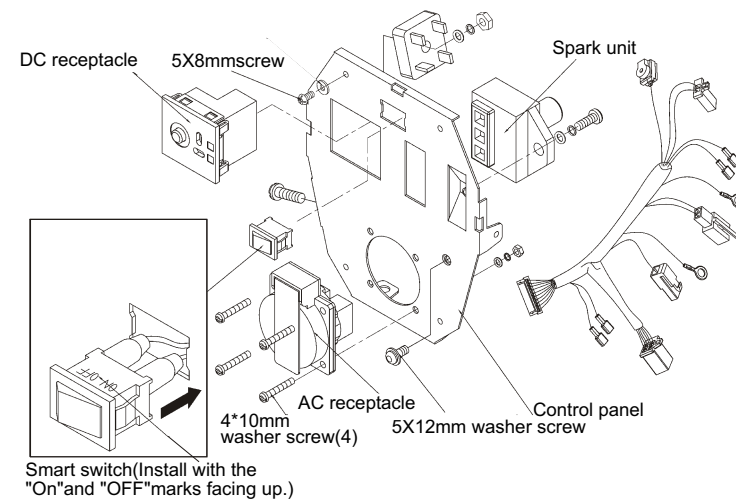

6. Control panel

6.1 Control panel

a. Removal/Installation

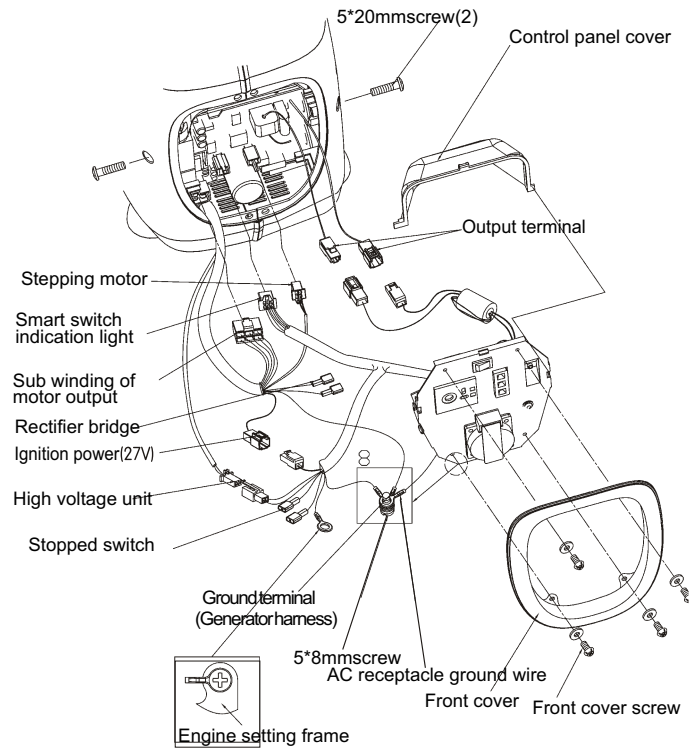

3) Check the diaphragm tube for deterioration, crack and oil leakage.

If there is any abnormality in the diaphragm tube, replace the tube.

4) Check to see whether water and foreign material have been accumulated in the fuel pump.

If there is water or foreign material accumulated in the pump, replace the fuel pump.

5) After assembly, check for gasoline leakage from each part.

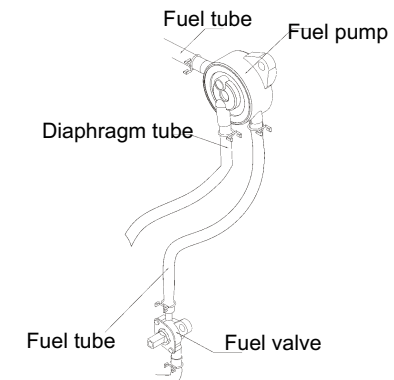
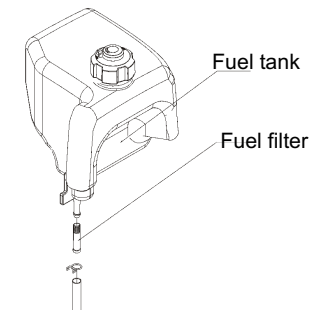

4. Muffler

4.1 Muffler

a. Disassembly/Reassembly

Note: Muffler removal/installation must be performed with the engine cold.

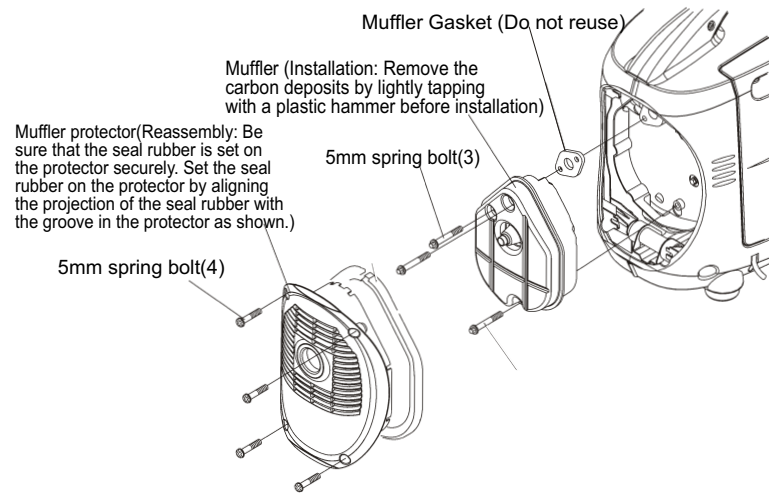

■ Throttle control motor

Measure the resistance between the terminals

Standard resistance	Between 1 and 3: 50-70 Ω Between 2 and 4: 50-70 Ω
---------------------	--

If the resistance is outside the specification, replace the throttle control motor.

Operation check:

Start the engine and stop it (several times). Be sure that the throttle control motor functions and the carburetor throttle arm moves properly.

If the throttle control motor does not operator properly, replace.

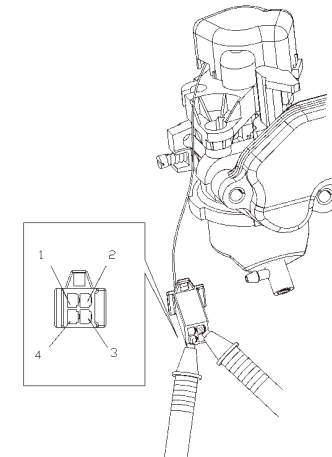

■ Pilot screw

Turn the pilot screw in until it is lightly seated, then turn the screw out the required number of turns. (2 turns)

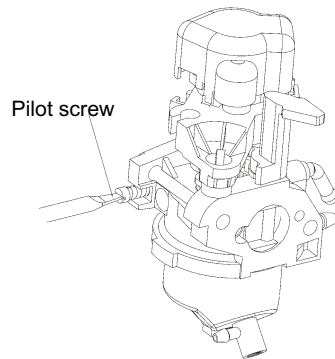

■ Throttle stop screw

Install the throttle stop screw after installing the pilot jet. Install so that the throttle valve is at full close position and the screw end does not come out of the bracket.

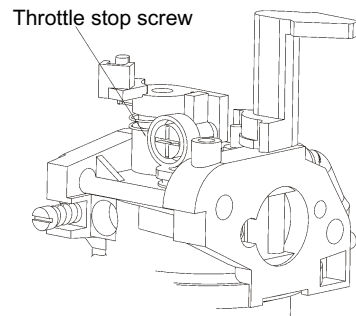

5. Carburetor

5.1 Carburetor

a. Removal/Installation



Gasoline is highly flammable and explosive. You can be burned or seriously injured when handling fuel. Keep heat, sparks, and flame away. Wipe up spills immediately. Loosen the drain screw to drain the carburetor thoroughly before removal.

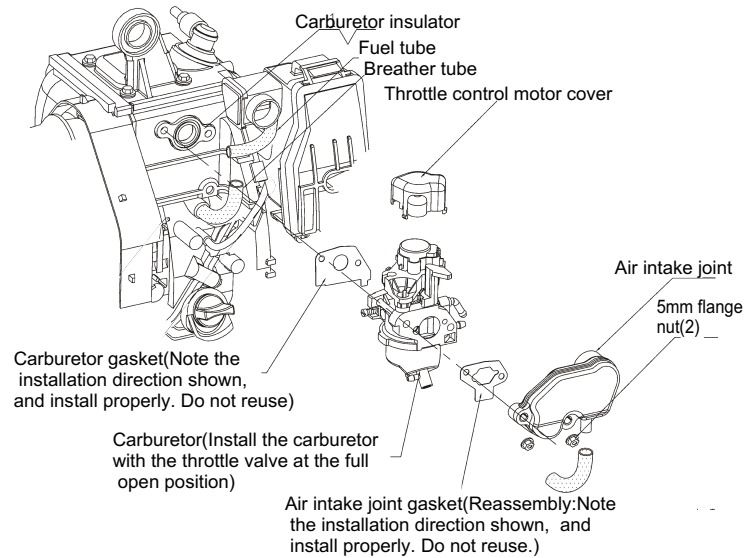

b. Removal/ Installation

Throttle control motor (Stepping motor)



Gasoline is highly flammable and explosive. You can be burned or seriously injured when handling fuel. Keep heat, sparks, and flame away. Wipe up spills immediately. Loosen the drain screw to drain the carburetor thoroughly before removal.

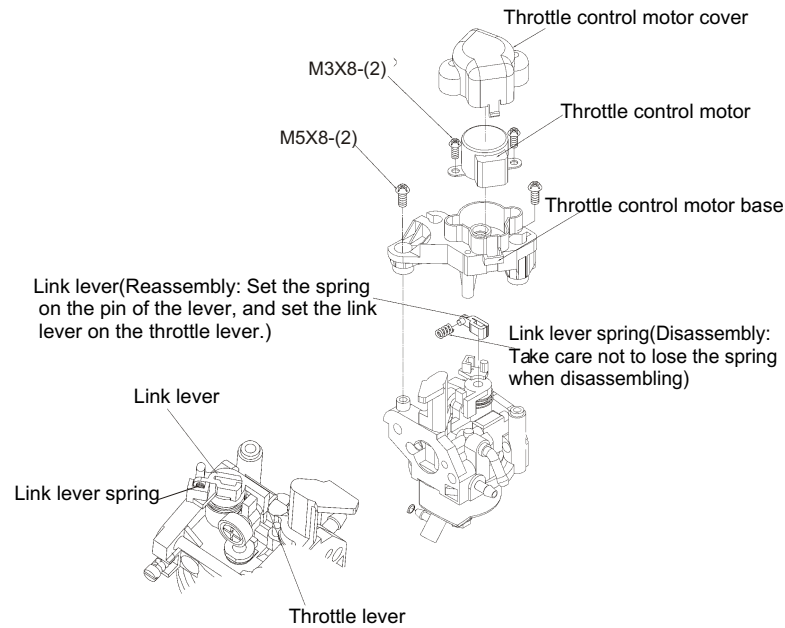

■ Carburetor



Gasoline is highly flammable and explosive. You can be burned or seriously injured when handling fuel. Keep heat, sparks, and flame away. Wipe up spills immediately. Loosen the drain screw to drain the carburetor thoroughly before removal.

